

PHILIPS

Data handbook



Electronic
components
and materials

Components and materials

Book C16

1986

Permanent magnet materials

PERMANENT MAGNET MATERIALS

	<i>page</i>
General	
Introduction	3
Survey of permanent magnet materials	5
Manufacturing technology	6
Typical demagnetization curves	9
Permanent magnet theory	15
Symbols.	24
Conversion of units	25
Size and shape tolerances	27
Indication of tolerances on engineering drawings	29
Specifying the magnetic axis and direction of magnetization	35
Recommendations for magnetization and demagnetization	40
Inspecting permanent magnets	41
Design advisory service	42
Computer-aided design service	43
Applications of permanent magnets	50
Ferroxdure	
Introduction	56
Temperature coefficients	59
Material specifications	61
Magnet type lists	101
Rare-earth magnet materials	
Introduction	131
Properties of RES190	135
Properties of RES270	143
Magnet type lists	141

DATA HANDBOOK SYSTEM

Our Data Handbook System comprises more than 60 books with specifications on electronic components, subassemblies and materials. It is made up of four series of handbooks:

ELECTRON TUBES	BLUE
SEMICONDUCTORS	RED
INTEGRATED CIRCUITS	PURPLE
COMPONENTS AND MATERIALS	GREEN

The contents of each series are listed on pages iv to viii.

The data handbooks contain all pertinent data available at the time of publication, and each is revised and reissued periodically.

When ratings or specifications differ from those published in the preceding edition they are indicated with arrows in the page margin. Where application information is given it is advisory and does not form part of the product specification.

Condensed data on the preferred products of Philips Electronic Components and Materials Division is given in our Preferred Type Range catalogue (issued annually).

Information on current Data Handbooks and on how to obtain a subscription for future issues is available from any of the Organizations listed on the back cover.

Product specialists are at your service and enquiries will be answered promptly.

ELECTRON TUBES (BLUE SERIES)

The blue series of data handbooks comprises:

- T1** Tubes for r.f. heating
- T2a** Transmitting tubes for communications, glass types
- T2b** Transmitting tubes for communications, ceramic types
- T3** Klystrons
- T4** Magnetrons for microwave heating
- T5** Cathode-ray tubes
Instrument tubes, monitor and display tubes, C.R. tubes for special applications
- T6** Geiger-Müller tubes
- T8** Colour display systems
Colour TV picture tubes, colour data graphic display tube assemblies, deflection units
- T9** Photo and electron multipliers
- T10** Plumbicon camera tubes and accessories
- T11** Microwave semiconductors and components
- T12** Vidicon and Newvicon camera tubes
- T13** Image intensifiers and infrared detectors
- T15** Dry reed switches
- T16** Monochrome tubes and deflection units
Black and white TV picture tubes, monochrome data graphic display tubes, deflection units

SEMICONDUCTORS (RED SERIES)

The red series of data handbooks comprises:

- S1 Diodes**
Small-signal silicon diodes, voltage regulator diodes (< 1,5 W), voltage reference diodes, tuner diodes, rectifier diodes
- S2a Power diodes**
- S2b Thyristors and triacs**
- S3 Small-signal transistors**
- S4a Low-frequency power transistors and hybrid modules**
- S4b High-voltage and switching power transistors**
- S5 Field-effect transistors**
- S6 R.F. power transistors and modules**
- S7 Surface mounted semiconductors**
- S8 Devices for optoelectronics**
Photosensitive diodes and transistors, light-emitting diodes, displays, photocouplers, infrared sensitive devices, photoconductive devices.
- S9 Power MOS transistors**
- S10 Wideband transistors and wideband hybrid IC modules**
- S11 Microwave transistors**
- S12 Surface acoustic wave devices**
- S13 Semiconductor sensors**

INTEGRATED CIRCUITS (PURPLE SERIES)

The purple series of data handbooks comprises:

EXISTING SERIES

Superseded by:

IC1	Bipolar ICs for radio and audio equipment	IC01N
IC2	Bipolar ICs for video equipment	IC02Na and IC02Nb
IC3	ICs for digital systems in radio, audio and video equipment	IC01N, IC02Na and IC02Nb
IC4	Digital integrated circuits CMOS HE4000B family	
IC5	Digital integrated circuits – ECL ECL10 000 (GX family), ECL100 000 (HX family), dedicated designs	IC08N
IC6	Professional analogue integrated circuits	
IC7	Signetics bipolar memories	
IC8	Signetics analogue circuits	IC11N
IC9	Signetics TTL logic	IC09N and IC15N
IC10	Signetics Integrated Fuse Logic (IFL)	IC13N
IC11	Microprocessors, microcomputers and peripheral circuitry	IC14N

NEW SERIES

IC01N	Radio, audio and associated systems Bipolar, MOS	(published 1985)
IC02Na	Video and associated systems Bipolar, MOS Types MAB8031AH to TDA1524A	(published 1985)
IC02Nb	Video and associated systems Bipolar, MOS Types TDA2501 to TEA1002	(published 1985)
IC03N	Integrated circuits for telephony	(published 1985)
IC04N	HE4000B logic family CMOS	
IC05N	HE4000B logic family – uncased ICs CMOS	(published 1984)
IC06N*	High-speed CMOS; PC74HC/HCT/HCU Logic family	(published 1986)
IC07N	High-speed CMOS; PC54/74HC/HCT/HCU – uncased ICs Logic family	
IC08N	ECL 10K and 100K logic families	(published 1984)
IC09N	TTL logic series	(published 1984)
IC10N	Memories MOS, TTL, ECL	
IC11N	Linear LSI	(published 1985)
IC12N	Semi-custom gate arrays & cell libraries ISL, ECL, CMOS	
IC13N	Semi-custom Integrated Fuse Logic	(published 1985)
IC14N	Microprocessors, microcontrollers & peripherals Bipolar, MOS	(published 1985)
IC15N	FAST TTL logic series	(published 1984)

Note

Books available in the new series are shown with their date of publication.

* Supersedes the IC06N 1985 edition and the Supplement to IC06N issued Autumn 1985.

COMPONENTS AND MATERIALS (GREEN SERIES)

The green series of data handbooks comprises:

- C1 Programmable controller modules**
PLC modules, PC20 modules
- C2 Television tuners, coaxial aerial input assemblies, surface acoustic wave filters**
- C3 Loudspeakers**
- C4 Ferroxcube potcores, square cores and cross cores**
- C5 Ferroxcube for power, audio/video and accelerators**
- C6 Synchronous motors and gearboxes**
- C7 Variable capacitors**
- C8 Variable mains transformers**
- C9 Piezoelectric quartz devices**
- C10 Connectors**
- C11 Varistors, thermistors and sensors**
- C12 Potentiometers, encoders and switches**
- C13 Fixed resistors**
- C14 Electrolytic and solid capacitors**
- C15 Ceramic capacitors**
- C16 Permanent magnet materials**
- C17 Stepping motors and associated electronics**
- C18 Direct current motors**
- C19 Piezoelectric ceramics**
- C20 Wire-wound components for TVs and monitors**
- C21* Assemblies for industrial use**
HNIL FZ/30 series, NORbits 60-, 61-, 90-series, input devices
- C22 Film capacitors**

* To be issued shortly.

GENERAL

INTRODUCTION

Modern magnets are far removed from the traditional idea of a U-shaped iron bar. Today, magnets are available in a variety of shapes to suit many applications, and the introduction of magnetic alloys and magnetic-oxide based ceramics has made the simple iron magnet the exception rather than the rule. Advances in magnet technology over the past 50 years have naturally led to an increase in the number of applications. According to some estimates, the modern household contains more than forty magnets, ranging from the refrigerator door catch to the field magnets of the record player motor.

Although essentially a bulk material property, magnetism is often explained using a model of the atomic structure of matter. In the classical atomic model, spinning negatively charged electrons revolve around a positively charged nucleus. The motion of these electrons can be regarded as a current loop which give rise to a magnetic dipole, in the same way as a current flowing through a conductor produces a magnetic field.

In a non-magnetic material, these magnetic dipoles are randomly oriented, and produce no net magnetic moment in the bulk material.

In a magnetic material, however, the dipoles align themselves locally, in regions called *domains*. These domains are usually aligned randomly throughout the material and so produce no net magnetic moment. In the presence of an external magnetic field, domains already aligned with the field grow at the expense of non-aligned domains. The bulk material then has a net magnetic moment and is said to be *polarized in* the field direction. As field strength increases, the aligned domains expand until, finally, no non-aligned domains remain. The material is then said to be *saturated*.

The ease with which a magnetic material can be polarized depends upon its microstructure. Likewise, this affects its behaviour when the magnetizing field is removed; the domains then resist returning to the previous disorganized state, and a residual polarization remains known as the *remanence*. To reduce the polarization to zero, a field in the reverse direction must be applied; the magnitude of this field is known as the *coercivity* of the material. This is an important property of a magnetic material, its value indicates the material's magnetic hardness. Soft magnetic materials, used, for example, in transformers and flux conductors, have coercivities of only a few amp/metre. Permanent magnets are produced from hard magnetic material, which is the general term for materials with coercivities exceeding 1 kA/m. This is the lower limit for hard magnetic materials; in general, the coercivities of such materials are considerably higher. Some of the hard magnetic materials in this data handbook have coercivities in excess of 1200 kA/m.

The creation of a permanent magnet requires energy. This energy is derived from the magnetizing field and is stored in the magnet, which thereafter can sustain a magnetic field itself, without power dissipation, power sources or electrical connections. A permanent magnet thus behaves as an energy source. The balance between internal energy and external energy depends on the magnetic load, which can consist of an air gap and/or an external magnetic field.

Normally, a magnet is an integral part of a construction, therefore mechanical as well as electrical properties have to be considered. Moreover, each application has its own special requirements, so a range of materials must be available if the user is to find one that fully satisfies his needs. The following sections provide the relevant data on our extensive range of magnetic materials, and give some application information to enable the user to make the most efficient use of the materials described. Should further information or technical assistance be needed, please contact our technical departments.

SURVEY OF PERMANENT MAGNET MATERIALS

There is a wide range of electrical and mechanical requirements encountered in magnetic systems, and no one material exists that satisfies all of them. However, it is usually possible to find a suitable material within our range. Selection will be based on magnetic and mechanical considerations, magnetic configuration and the cost effectiveness of the resulting system (not necessarily the same as magnet cost).

The family tree shows our range of permanent magnet materials.

GENERAL NOTES

Units

In the following tables the main properties of the various materials are given in SI units. More detailed information is to be found in the relative data pages further down the book, where c.g.s. units are also listed.

Typical values

The term typical values ("typ.") denotes a value which frequently occurs. Typical values enable the user to compare various grades; they are intended to be average or mean values.

Minimum values

The minimum values quoted are guaranteed for specified test pieces.

Minimum values of B_r and H_{cB} do not occur simultaneously. The minimum value of B_r coincides with an H_{cB} well above the quoted typical value, whereas the minimum value of H_{cB} is coupled with a high value of B_r .

Material designation

The material designation consists of the name of the material:

FXD (Ferroxdure),

RES (Rare Earth alloys)

followed by a type classification. Plastic bonded Ferroxdure grades include a letter for the bonding material:

P = flexible thermoplastic,

SP = rigid thermoplastic.

MANUFACTURING TECHNOLOGY

Magnets are often identified by the way they are made or by their construction. Knowledge of their manufacture is useful since it provides an indication of their mechanical properties and tolerances, as well as of the possible shapes they can be supplied in. Since the magnet is usually an integral part of its mechanical system, these factors must be considered when selecting a magnetic material for a particular application.

Our permanent magnets fall into two main groups: metal alloy and hard ferrite. These groups can be further subdivided according to the manufacturing technology; sintering and plastic bonding. Finally, magnets can be produced with isotropic or anisotropic magnetic properties, the latter being produced during manufacture by imparting an enhanced magnetic direction to the material using an external field. Limitations on the possible directions are discussed in the data section.

Sintered magnet production

Sintered magnets are formed by compacting powders, granules or slurry (powder/water mixture) under pressure, and then sintering the compact at controlled temperatures. During sintering, the material shrinks, the density increasing by as much as 40%. This increase in density improves the magnetic properties of the material considerably.

The compact is usually formed in a die, which is designed such that after sintering, the magnet can be shaped with minimum machining. For anisotropic magnets, an external magnetic field applied during the compaction stage imparts the enhanced magnetic direction.

The method of manufacture of these products and their ceramic nature restrict them to relatively simple shapes. Moreover, for anisotropic Ferroxdure magnets the direction of magnetization is normally restricted to the direction of compaction. Nevertheless, for most applications sintered magnets are the natural choice since they provide an excellent compromise between good magnetic properties and economy.

- Sintered rare-earth magnets are formed by compacting powder or granules in an inert atmosphere under pressure. It then follows closely the method used for anisotropic Ferroxdure magnets but a heat treatment is added to increase the coercive force. Machining can only be done by silicon carbide or diamond grinding wheels.

Plastic bonded magnets

The magnets are produced from magnetic powders mixed with bonding agents, by methods common in the plastics industry, i.e. extrusion, injection moulding and pressing. In this way complex shapes are possible. Magnetic fields applied during the forming operation can provide anisotropic magnetic properties if these are required.

Plastic bonded magnets can be made to very fine tolerances, and machining is rarely needed. Their density, however, is low compared with sintered magnets, so their magnetic properties are generally inferior. Nevertheless, they are ideal for applications requiring complex shapes and magnetization patterns.

PERMANENT MAGNET MATERIALS

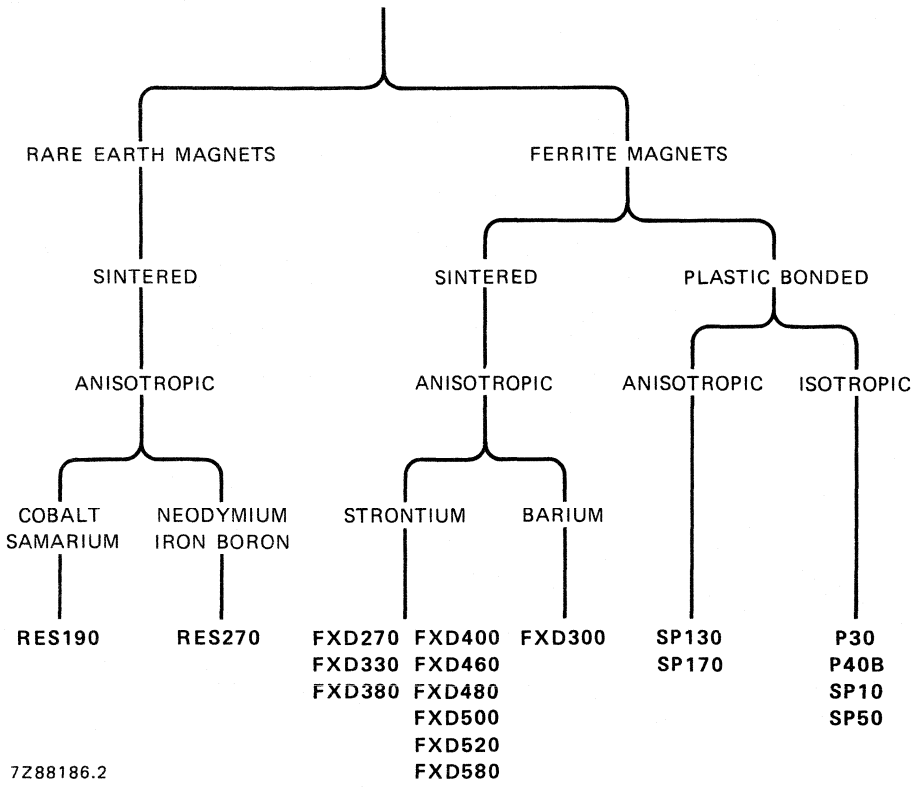

7Z88186.2

material designation	remanence		coercivity		polarization coercivity		max. BH product		$B_r \times H_cJ$	
	B_r (mT)		H_cB (kA/m)		H_cJ (kA/m)		$(BH)_{max}$ (kJ/m ³)		(kJ/m ³)	
	typ.	min.	typ.	min.	typ.	min.	typ.	min.	typ.	min.

FERROXDURE (sintered)

Anisotropic

FXD270	350	340	260	250	335	320	22,8	21,5	117	109
FXD330	370	360	245	230	255	240	25,5	24,1	94	86
FXD460	365	360	270	265	365	350	24,8	24,1	133	126
FXD380	390	380	265	250	275	260	28,2	26,9	107	99
FXD480	380	370	280	270	320	305	26,8	25,5	122	113
FXD580*	385	375	285	275	335	325	27,6	26,2	129	122
FXD300	400	390	160	145	165	150	29,5	28,0	66	59
FXD400	410	400	265	250	275	260	31,3	29,8	113	104
FXD500*	405	400	295	285	320	310	30,5	29,8	130	124
FXD520*	425	420	250	240	260	250	33,6	32,8	111	105

FERROXDURE (plastic bonded)

Isotropic

FXD SP10	80	75	58	54	190		0,9	0,8		
FXD P30	125	115	88	84	190		2,8	2,4		
FXD P40B	145	135	96	88	190		3,6	3,2		
FXD SP50	155	150	104	100	190		4,4	4		

Anisotropic

FXD SP130	240	230	175	167	240		11	10		
FXD SP170	270	260	190	185	220		—	—		

RARE-EARTH (sintered)

Anisotropic

RES 190	890	870	670	620	—	1100	154	144		
RES 270*	1100	—	750	—	835	—	216	—		

* Tentative data

TYPICAL DEMAGNETIZATION CURVES
FERROXDURE

7Z89384.1

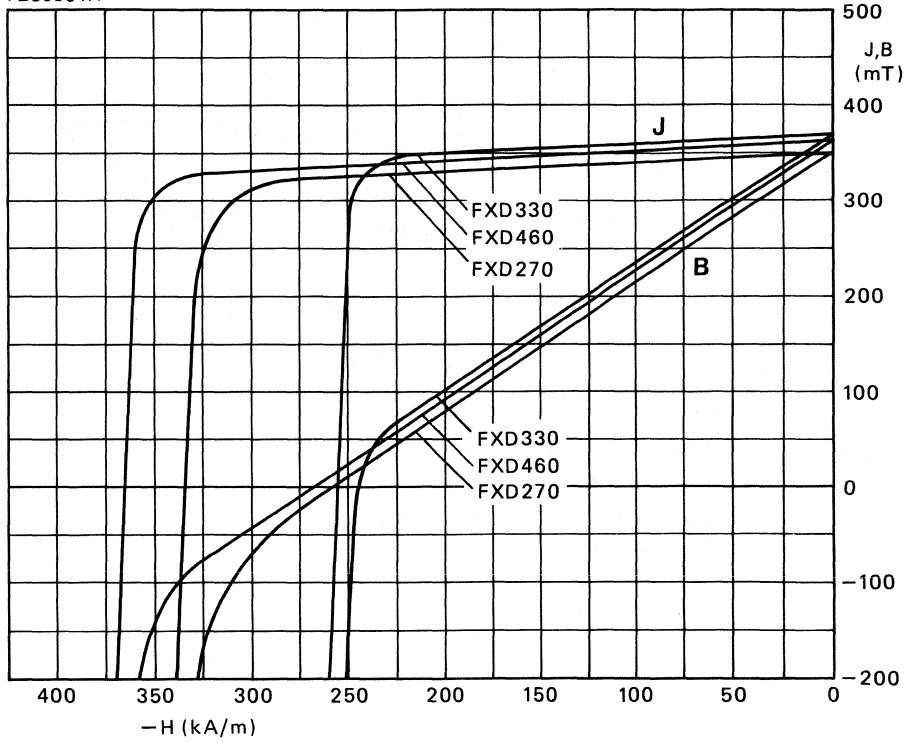

FERROXDURE

7Z89383.2

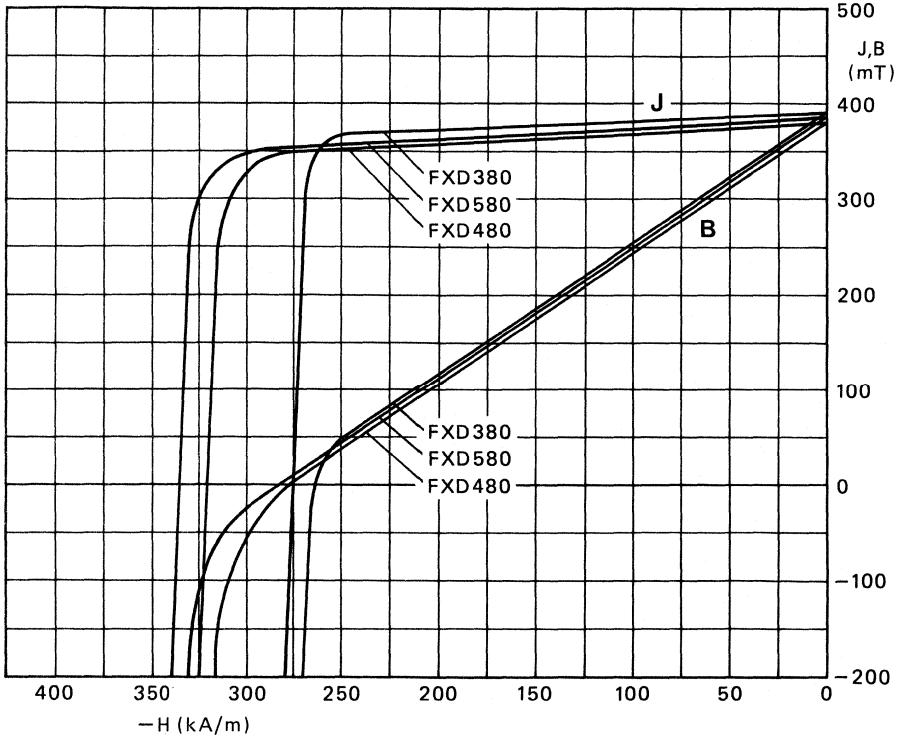

FERROXDURE

7Z89385.1

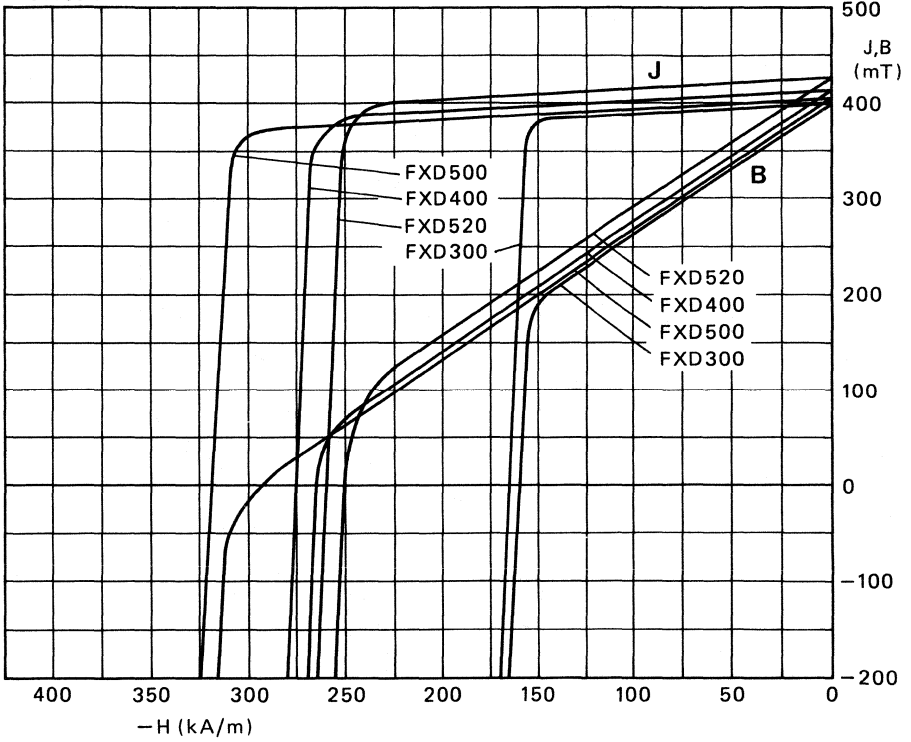

FERROXDURE

7Z70863.5

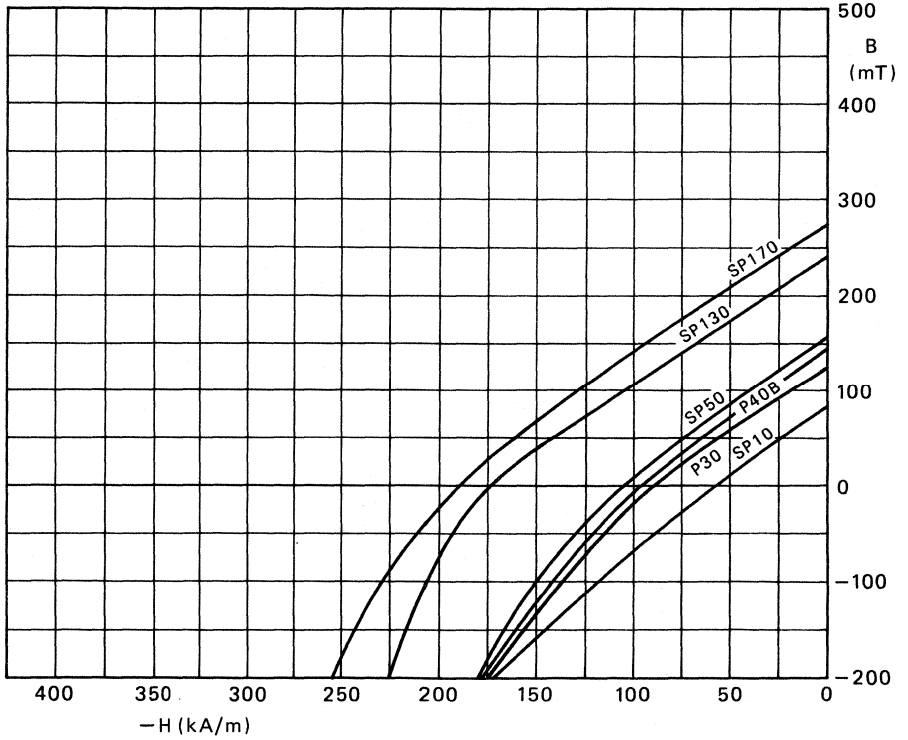

COBALT RARE EARTH

(sintered)

7Z89382.2

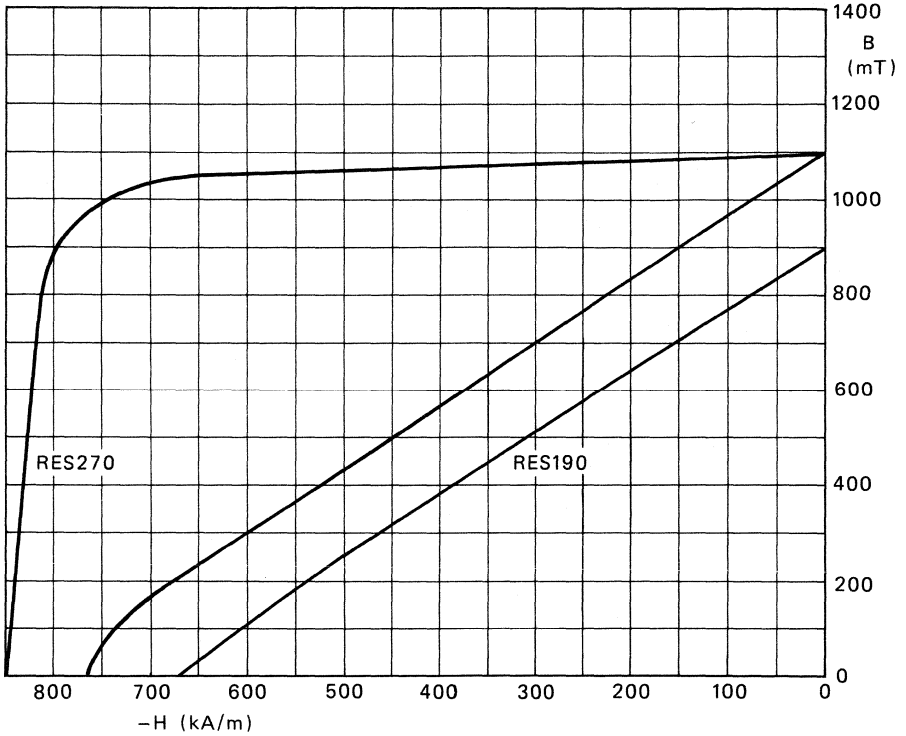

PERMANENT MAGNET THEORY

UNITS AND DEFINITIONS

Permanent magnet engineering has been more affected by the adoption of SI units than most other branches of technology. For this reason, quantities and expressions will be given here in SI units followed by the equivalent for c.g.s. units in parentheses. Terms and definitions are those recommended by the IEC, taken from Publication 50, Chapter 901.

THE HYSTERESIS LOOP

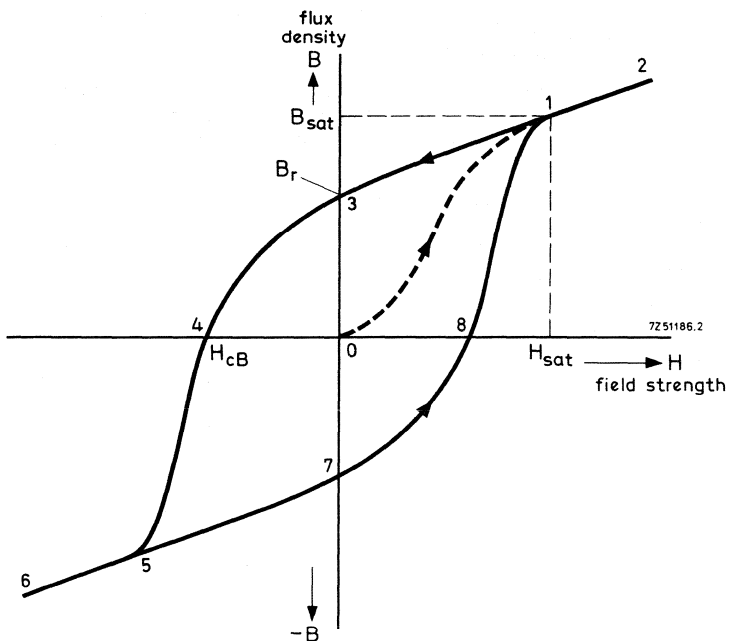

Fig. 1 Saturation hysteresis loop, variation of flux density with applied magnetic field strength H .

The reaction of a specimen of magnetic material to a magnetic field depends on the nature and history of the specimen and the magnitude and direction of the field. The behaviour can be described in terms of the applied field H and the resulting flux density B .

All possible combinations of B and H for a given material lie within a curve of the form shown in Fig. 1. This *hysteresis loop* represents the cycle of complete magnetization and demagnetization of the material. Within it, the working point of the material (BH) moves along minor loops and recoil lines.

The condition of a completely unmagnetized specimen can be represented by the origin of Fig. 1. If the applied field increases steadily from zero, the flux density in the specimen will increase so that the locus (BH) follows the curve 0-1, the initial magnetization curve. Further increase in H will cause B to increase at a rate that tends towards the permeability of free space $dB/dH = \mu_0$. Then the material no longer contributes to the increase in flux density and is said to be saturated. For practical purposes, saturation can be regarded as occurring at point 1: where the initial magnetization curve and the hysteresis loop start to coincide. The properties of the material corresponding to point 1 are *saturation flux density* and *saturation field strength*.

If, after saturation has been attained, the applied field is steadily reduced, the (BH) locus falls back along the line 2-3, reaching 3 when $H = 0$. The flux density that remains in the material, point 3, is termed the *remanence*, symbol B_r , of the material. Remanence is the flux density of a magnet in a closed magnetic circuit after saturation.

Increasing the applied field again, but in the reverse direction to the saturation field, causes the (BH) locus to follow the curve 3-4. This is the *demagnetization curve* or *second quadrant* of the hysteresis curve: the most important region in permanent magnet applications. When the value of reverse field is such as to cause the flux density in the material to reach zero, the field strength is termed the *coercivity*, symbol H_{CB} .

Further increasing the applied field drives the (BH) locus towards saturation (5 and 6) in the opposite direction. Once point 5 has been reached, the (BH) locus can be allowed to fall back to remanence at point 7 and so into the fourth quadrant.

INTRINSIC HYSTERESIS LOOP

The flux density plotted in Fig. 1 is the sum of the magnetic polarization J and the flux density B_0 due to the applied field:

$$B = J + B_0 = J + \mu_0 H$$

or, in c.g.s. units

$$B = 4\pi J + H.$$

J is also called the intrinsic flux density. If J is plotted against H , the effect of B_0 is excluded: the resultant loop is compared with the B - H loop in Fig. 2.

At saturation, the slope of the intrinsic hysteresis loop is zero. When the applied field is then removed, the polarization is the remaining flux density and hence the remanence of the material. The demagnetizing field necessary to remove the polarization is H_{cJ} , the intersection of the intrinsic loop and the H axis. It is called *polarization coercivity* and is greater than H_{cB} .

This difference depends on the slope of the loop near coercivity: if the slope is small the difference is large; if the slope approaches 90° , then the two coercivities for the material will be nearly the same.

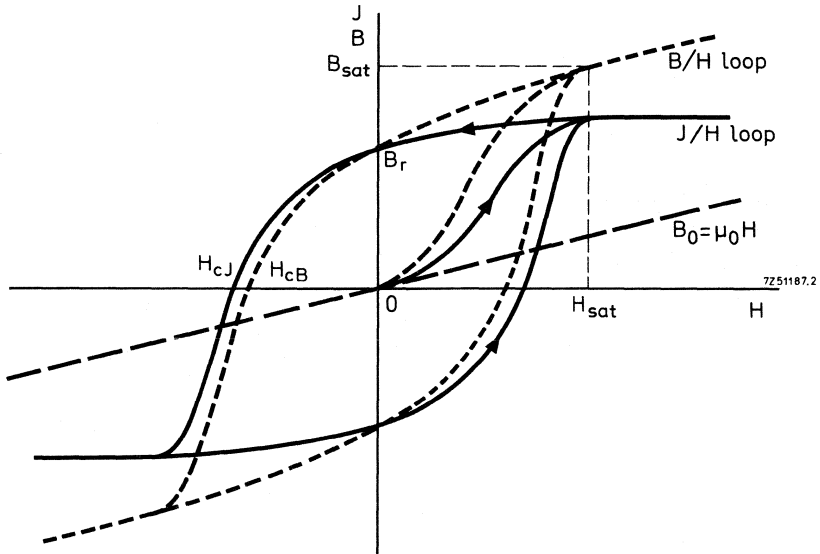

Fig. 2 Comparison of variations of flux density and polarization with applied field strength.

THE DEMAGNETIZATION CURVE

Complete hysteresis loops are important for soft magnetic materials where the material is usually subject to rapidly reversing applied fields, as in transformer cores. For hard (permanent) magnetic materials, which usually operate in a demagnetizing field (self or applied) the demagnetization characteristic is the more important. This lies in the second and fourth quadrants of the hysteresis loop, which are, in consequence, known as the demagnetization curve.

Figure 3 shows a typical demagnetization curve for a permanent magnet material. The graph is also marked with BH product contours. A curve of BH against B appears to the right of the B axis. The value of BH indicates the energy stored in the field external to the magnet per unit volume of magnet material.

In the SI system: $W = BH/2$; in the c.g.s. system: $W = BH/8\pi$.

The maximum value of BH, also called the *maximum energy product* or $(BH)_{max}$, corresponds to the point (B_d, H_d) ; it represents the point of optimum utilization of the magnet material and is one of the criteria for comparing the performance of different materials.

The value of $(BH)_{max}$ is quoted in kilojoules per cubic metre (SI) or megagauss-oersted (c.g.s.).

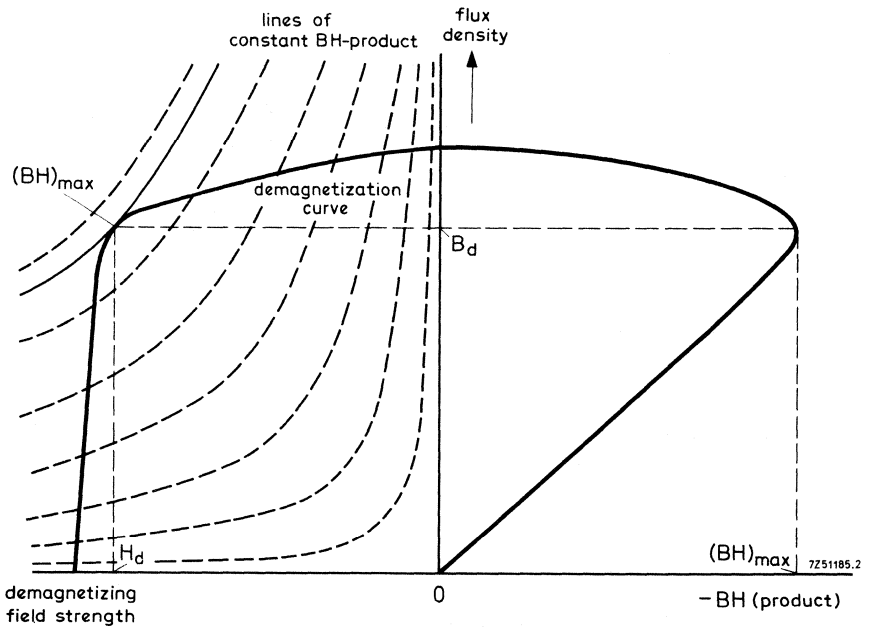

Fig. 3 Demagnetization curve with contours of constant BH-product, and BH-product curve.

RECOIL

The demagnetization curve represents the steady decrease in flux density with increasing demagnetization of the material. If a magnet is saturated and then subjected to a certain demagnetizing field less than the coercivity, the flux density in the magnet will be given for that reverse field by the demagnetization curve. Under practical conditions, however, the demagnetizing field experienced by the magnet is rarely constant: large or small variations will take place, depending on the application. What will happen if a magnet is subjected to a given value of demagnetizing field that is then reduced?

This situation is shown in Fig. 4. A saturated magnet is subjected to a demagnetizing field H_1 . This field is then reduced. The working point of the material does not follow the demagnetization curve back towards remanence, but moves along the curve C. If the demagnetizing field is reduced to zero, the working point follows the curve C to B_0 ; restoring the original value of demagnetizing field causes the working point to fall back to A_1 (H_1, B_1). In doing this the working point follows the curve D, thus tracing out a small loop in the process.

If instead of reducing to zero, the demagnetizing field falls only to H_2 , the working point moves to (B_2, H_2); restoring the original demagnetizing field causes a smaller loop to be traced.

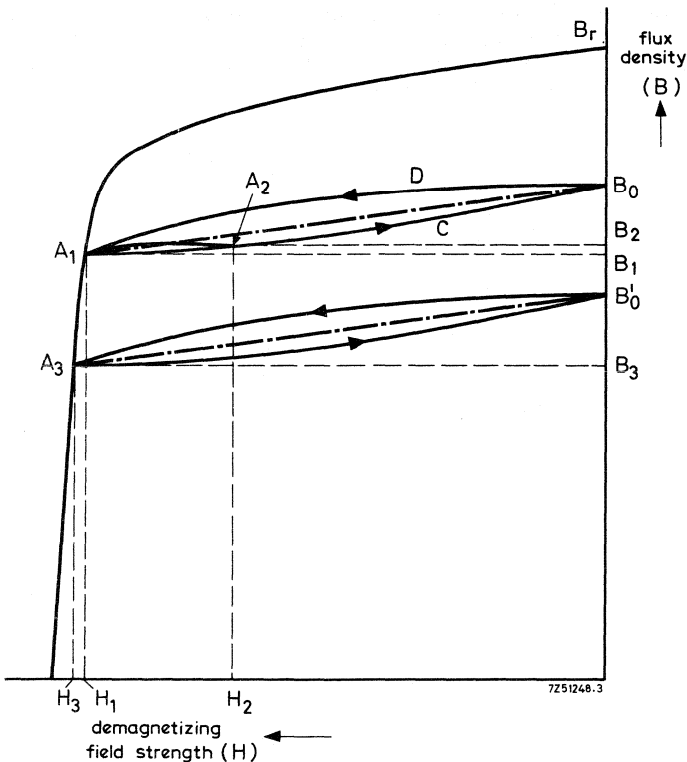

Fig. 4 Recoil lines.

For permanent magnet materials, these loops are usually of very small area, and can be represented as straight lines known as *recoil lines*. The slope of these recoil lines is the *recoil permeability*. The recoil permeability is usually about equal to the slope of the main demagnetizing curve at B_r .

If, after tracing out the loop $A_1CB_0DA_1$, the demagnetizing field is further increased to H_3 , the working point will move down the main demagnetization curve to $A_3 (B_3, H_3)$. Reducing the field to zero and then restoring it will cause the working point to follow the loop A_3B_0 , which corresponds to another recoil line parallel to the first.

TEMPERATURE COEFFICIENT

The rate of change of remanence or coercivity of a permanent magnet material with temperature is generally quoted in percent per kelvin:

$$\alpha_{B_r} = \frac{1}{B_r} \times \frac{dB_r}{dT} \times 100\%/K.$$

CURIE AND TRANSITION TEMPERATURES

At its Curie temperature a material becomes practically non-magnetic; any magnetization is lost and can only be restored by renewed saturation at a lower temperature. Most materials also exhibit a transition temperature. At this temperature their crystal structure is changed and magnetic properties permanently altered. The maximum permissible operating temperature of a permanent magnet material is set below the lower of these two temperatures.

MAGNETIC CIRCUIT DESIGN

The most common application of a permanent magnet material is the provision of a magnetic field to react with current-carrying conductors. Examples include loudspeakers, moving-coil meters and relays, and electric motors. In all cases, the cost of the final assembly depends on the size of the polarizing magnet, which depends, in turn, on the efficiency of the magnetic circuit.

In a given magnetic circuit, the size of the permanent magnet is at a minimum when the magnet is operated at its $(BH)_{\max}$ point. At this point, the energy available from the magnet is at a maximum. Of this energy, only a fraction, usually less than half, can be concentrated in the useful air gap. Energy considerations are, however, secondary. The object of magnetic circuit design is the provision of a magnetic field of sufficient strength and stability over the volume, and with the uniformity required for the application. It is desirable to do this with the minimum sized magnet commensurate with the other (mechanical, electrical and environmental) design requirements.

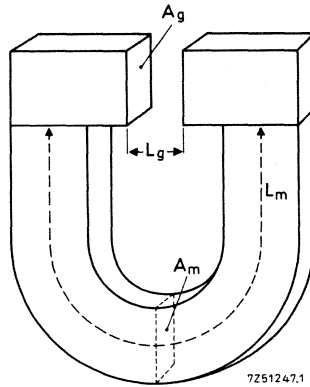

Fig. 5 Simple magnetic circuit.

Basic design method

Although computer-aided design methods have been in use for permanent-magnet systems for some time, it is possible, with practice, to form a close estimate of the design of a magnet system by simple manual calculation. This is usually done on the basis of a resistance analogue of the magnetic circuit. Magnetomotive force (the line integral of field strength, or, for a uniform field, field strength times length) is treated as voltage and total flux (the area integral of flux density, or, for a uniform field, flux density times area) is treated as current. In this analogy, reluctance (magnetomotive force divided by total flux) is the equivalent of resistance, and its reciprocal, permeance, is the equivalent of conductance. These relationships can be applied to the simple magnetic circuit of Fig. 5. We assume that all the energy is concentrated in the air gap, that is, there is no leakage. Then, the total magnet flux will equal the total gap flux:

$$\phi = B_m A_m = B_g A_g.$$

The magnetomotive force (F_m) across the magnet will be the same as that across the air gap:

$$F_m = H_m L_m = H_g L_g.$$

Since

$$B_g = \mu_0 H_g$$

(in the c.g.s. system, $\mu_0 = 1$ gauss/oersted; in the SI system, $\mu_0 = 4\pi 10^{-7}$ H/m)

$$B_m H_m = \mu_0 H_g A_g$$

In practice, however, not all the flux passes through the useful air gap, and not all the magnetomotive force appears across the gap. It is usual to represent these losses by two factors p and q respectively:

$$B_m A_m = p \mu_0 H_g A_g \tag{1}$$

and

$$H_m L_m = q H_g L_g \tag{2}$$

Leakage and loss factors

Factor p introduced above is the *leakage factor* of the system:

$$p = \frac{\text{total magnet flux}}{\text{total flux in useful air gap}}$$

where the total magnet flux is measured through the magnet area passing through the *neutral point* of the magnet. The neutral point is usually midway along the magnet. Estimates of leakage factor can be made by calculation but the usual procedure is to adopt known leakage factors of similar measured systems.

Factor q is the *loss factor*. It is due to the various reluctances in series with the air gap such as pole pieces and joints:

$$q = \frac{\text{magnet magnetomotive force}}{\text{gap magnetomotive force}}$$

The value of q normally lies between 1.05 and 1.2 - it is usual to take q = 1, 1 as a first estimate, thus increasing the magnet length by 10%.

Working point and load line

Rearranging eqs (1) and (2) yields

$$A_m = \frac{p \mu_0 H_g}{B_m} A_g \tag{3}$$

and

$$L_m = \frac{q H_g}{H_m} L_g \tag{4}$$

Multiplying eqs (3) and (4) gives

$$A_m L_m = V_m = \frac{p q \mu_0 H_g^2 V_g}{B_m H_m} \tag{5}$$

where V_m and V_g are the magnet and gap volumes respectively. The term $B_m H_m$ is the energy product of the material. It can be seen from eq. (5) that the magnet volume will be a minimum when the energy product is maximum, as stated previously. The components of the energy product are the *working point* of the magnet.

Equations (1) and (2) can also be combined to give

$$B_m = \frac{p A_g L_m}{q A_m L_g} \mu_0 H_m \tag{6}$$

For a given magnet and gap dimensions, eq. (6) is a straight line plotted in Fig. 6 as OP_1 . The slope of this line is

$$\cot\alpha = \frac{B_m}{H_m} = \frac{\rho A_g L_m \mu_0}{q A_m L_g}$$

This line intersects the demagnetization curve for the material at the working point. The line itself is known as the load line for the application. Moreover, its slope, B_m/H_m , is the permeance of the magnetic circuit. For maximum efficiency (minimum magnet volume), the permeance should be B_d/H_d .

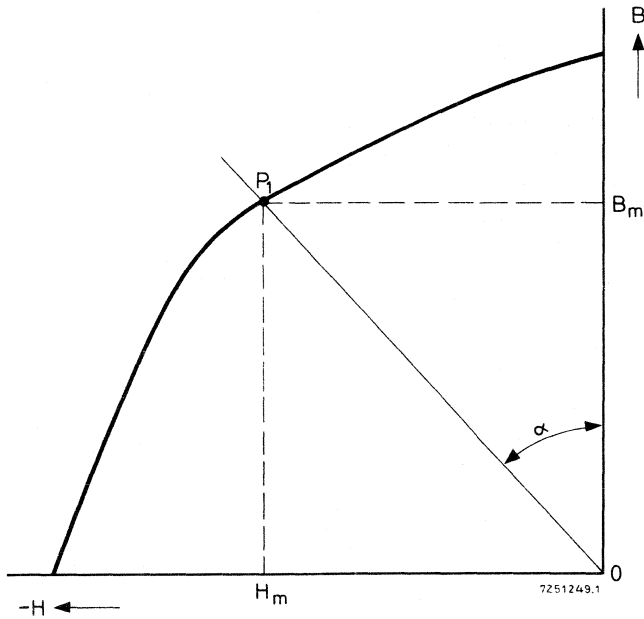

Fig. 6 Demagnetization curve with load line and recoil line.

SYMBOLS

αB_r	= temperature coefficient of remanence
A_g	= cross-sectional area of the air gap perpendicular to the lines of flux
A_m	= cross-sectional area of permanent magnet perpendicular to direction of magnetization
B	= (magnetic) flux density/(magnetic) induction
B_d	= flux density at $(BH)_{max}$
B_g	= flux density (induction) in the air gap
$(BH)_{max}$	= maximum BH product on the demagnetization curve
J	= magnetic polarization
B_m	= flux density (induction) in the magnet
B_r	= remanence, residual flux density, residual induction
B_{sat}, B_s	= saturation flux density/saturation induction
F_m	= magnetomotive force
H	= (magnetic) field strength
H_{cB}	= coercivity
H_{cJ}	= polarization coercivity
H_d	= demagnetizing field strength at $(BH)_{max}$
H_g	= field strength in the air gap
H_m	= demagnetizing field strength in the magnet
H_{sat}, H_s	= saturation field strength, field strength required for saturation
$l_g (L_g)$	= length of the air gap parallel to the lines of flux
$l_m (L_m)$	= effective magnetic length of magnet
N	= total number of turns
A	= permeance
R_m	= reluctance
μ	= permeability/normal permeability
μ_{rec}	= recoil permeability
ϕ	= magnetic flux/total flux

CONVERSION OF UNITS

conversion scale is on next page

SI units	→	c.g.s. units
1 T = 1 Wb/m ² = 1 Vs/m ²		= 10 ⁴ Gs = 10 kGs
1 mT		= 10 Gs
1 A/m		= 4π × 10 ⁻³ Oe = 0,01257 Oe
1 kA/m		= 4π Oe = 12,57 Oe
1 Wb = 1 Vs = 1 Tm ²		= 10 ⁸ Mx
1 μWb		= 100 Mx
μ ₀ = 4π × 10 ⁻⁷ H/m = 1,257 μH/m		μ ₀ can be replaced by 1 Gs/Oe
1 H/m = 1 Vs/Am		
1 J/m ³ = 1 TA/m		= 4π × 10 GsOe = 125,7 GsOe
1 kJ/m ³ = 1 mJ/cm ³		= 4π × 10 ⁻² MGsOe = 0,1257 MGsOe
1 J = 1 Ws = 1 Nm		= 10 ⁷ erg
1 N = 1 kgm/s ² = 0,1019 kilogramme-force		= 10 ⁵ dynes

SI units	←	c.g.s. units
10 ⁻⁴ = 0,1 mT		= 1 Gs (gauss)
0,1 T = 100 mT		= 1 kGs
10 ³ /(4π) A/m = 1/(4π) kA/m = 0,07958 kA/m		= 1 Oe (oersted)
0,01 μWb		= 1 Mx (maxwell)
10 μWb		= 1000 Mx
10 ² /(4π) mJ/m ³ = 7,958 mJ/m ³		= 1 GsOe
10 ² /(4π) kJ/m ³ = 7,958 kJ/m ³		= 1 MGsOe
10 ⁻⁷ J		= 1 erg

Energy in the field external to the magnetic material, per unit volume of the permanent magnet:

SI system: BH/2

c.g.s. system: BH/8π

GENERAL

MGs Oe Oe kA/m kJ/m³

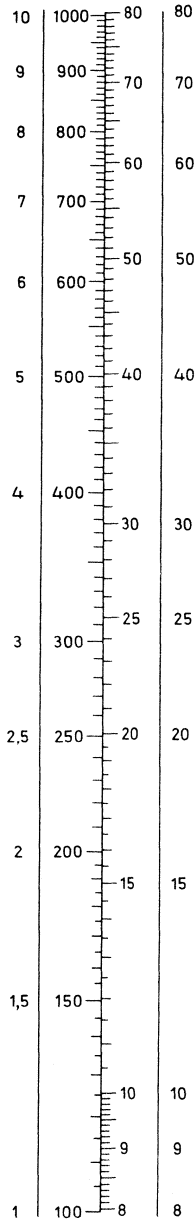

The range of this scale may be extended by multiplying the values on both sides by the same power of 10.

7Z70902

SIZE AND SHAPE TOLERANCES

In the interest of rational and economical manufacture, tolerances should be as wide as possible to avoid additional machining. Tolerances shown in these data are those which can be expected from our mass production techniques. Alternative tolerances, where required, are subject to agreement between manufacturer and user. The tolerances may be indicated as defined in ISO recommendation R1101 (see following pages).

SINTERED FERROXDURE AND RARE EARTH

Sintered magnets are manufactured by pressing and subsequent sintering. During the sintering process the material shrinks, giving rise to relatively wide tolerances: shapes should be as simple as possible. Being hard and brittle, the magnets can be machined only by grinding.

Dimensional tolerances

Unground surfaces (dimensions perpendicular to Magnetic Axis)

below 10 mm	$\pm 0,25$ mm
from 10 mm upwards	± 2 to $\pm 2,5\%$ (product dependent)
Between two ground parallel surfaces	$\pm 0,05$ to $\pm 0,3$ mm (product dependent)

Shape tolerances

In addition to dimensional inaccuracies, sintered magnets may exhibit shape inaccuracies due to shrinkage, such as out-of-parallelism, out-of-squareness and eccentricity. Specific requirements should be negotiated between manufacturer and user.

PLASTIC-BONDED FERROXDURE

Bonded magnets are manufactured without sintering (no shrinkage) and therefore tolerances are smaller than in the case of sintered magnets. Machining after shaping should, for economic reasons, be avoided.

Dimensional tolerances

FXD-SP

below 10 mm	$\pm 0,05$ to $0,1$ mm
10 mm to 30 mm	$\pm 0,2$ to $0,2$ mm
above 30 mm up to 60 mm	$\pm 0,2$ to $0,3$ mm
above 60 mm	$\pm 0,5\%$

FXD-P

below 10 mm	$\pm 0,2$ to $0,3$ mm
10 mm to 30 mm	$\pm 0,3$ to $0,4$ mm
above 30 mm up to 50 mm	$\pm 0,4$ to $0,5$ mm
above 50 mm	$\pm 1\%$

Note: FXD-P magnets are subject to permanent deformation when compressed.

INDICATION OF TOLERANCES ON ENGINEERING DRAWINGS (FORM AND POSITION)

This standard is in accordance with the ISO-Recommendation R1101-1969 "Tolerances of form and of position"

1. SCOPE

- 1.1 This document gives the principles of the symbolization and of the indication on technical drawings of tolerances of form and of position.
- 1.2 Although the system of indicating tolerances of form and of position is based on practical manufacture and inspection, such indications do not imply the use of any particular method or production, measurement or gauging.

For a general introduction on the subject of geometrical tolerances of form and of position, see UN-D 601.

2. GENERAL DEFINITIONS AND REMARKS

- 2.1 A tolerance of form or of position of a geometrical element (point, line, surface or median plane) defines the zone within which this element is to be contained (see note 1).
- 2.2 According to the characteristic which is to be toleranced and the manner in which it is dimensioned, the tolerance zone is one of the following:
 - the area within a circle;
 - the area between two concentric circles;
 - the area between two parallel lines or two parallel straight lines;
 - the space within a sphere;
 - the space within a cylinder or between two coaxial cylinders;
 - the space between two parallel surfaces or two parallel planes;
 - the space within a parallelepiped.
- 2.3 In the absence of a more restrictive indication, an element may be of any form or orientation within this tolerance zone.
When necessary an explanatory note may be added to the symbol or may be given in the absence of an appropriate symbol.
- 2.4 Unless otherwise specified the tolerance applies to the whole length or surface of the considered feature.
- 2.5 The datum feature to which tolerances of orientation, position and run-out are related.
- 2.6 The form of a datum feature should be sufficiently accurate for its purpose and it may therefore be necessary, in some cases, to specify tolerances of form for the datum features (see note 2).

Notes

1. The form of a single feature is deemed to be correct, when the distance of its individual points from a superimposed surface of ideal geometrical form is equal to or less than the value of the specified tolerance. The orientation of the ideal surface should be chosen so that the maximum distance between it and the actual surface of the feature concerned is the least possible value.

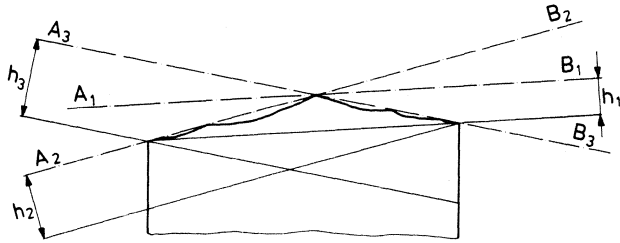

Fig. 1.

Possible orientations of the ideal surface: A_1-B_1 A_2-B_2 A_3-B_3

Corresponding maximum distances:

h_1 h_2 h_3

In the case of Figure 1:

$h_1 < h_2 < h_3$

Therefore the orientation of the ideal surface is A_1-B_1 , and h_1 is to be equal to or less than the specified tolerance.

2. In some cases it may also be desirable to indicate the position of certain points which will possibly form a temporary datum feature for both manufacture and inspection.

3. SYMBOLS

The following symbols represent the types of characteristics to be controlled by the tolerance.

Characteristics to be tolerated		Symbols
Form of single features	Straightness	—
	Flatness	
	Circularity (Roundness)	
	Cylindricity	
	Profile of any line	
	Profile of any surface	
Orientation of related features	Parallelism	
	Perpendicularity (Squareness)	
	Angularity	
Position of related features	Position	
	Concentricity and coaxiality	
	Symmetry	
Run-out		

4. EXAMPLES OF INDICATION AND INTERPRETATION OF TOLERANCES OF FORM AND OF POSITION

Characteristics to be tolerated	Example of indication	Interpretation	Description
Straightness			The axis of the cylinder to the dimension of which the tolerance frame is connected should be contained in a cylindrical zone of diameter 0,08.
			Any generator of the cylindrical surface indicated by the arrow should be contained between two parallel straight lines, 0,1 apart.
			If two different straightness tolerances are applied to two directions on the same surface, the straightness tolerance zone of this surface is 0,05 in that direction shown on the left-hand view and 0,1 in that direction shown on the right-hand view
Flatness			The surface should be contained between two parallel planes 0,05 apart.
Circularity			The circumference of the disc should be contained between two co-planar concentric circles 0,03 apart.
Cylindricity			The considered surface should be contained between two coaxial cylinders the radii of which differ by 0,1.
Profile tolerance of any line			In each section, parallel to the plane of projection the considered profile should be contained between two lines enveloping circles of diameter 0,04 the centres of which are situated on a line having the geometrically correct profile.
Profile tolerance of any surface			The considered surface should be contained between two surfaces enveloping spheres of diameter 0,02 the centres of which are situated on a surface having the geometrically correct form.

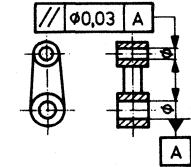
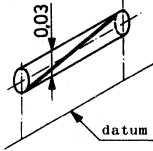
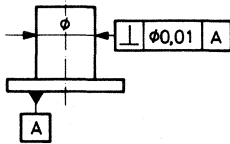
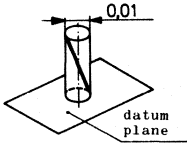
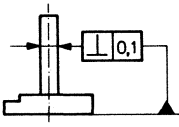
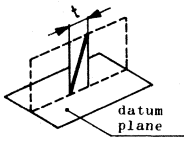
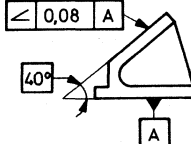
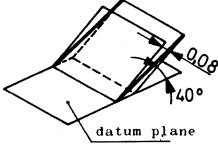
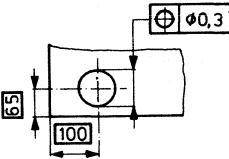
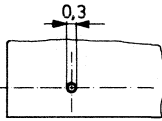
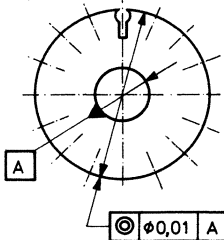
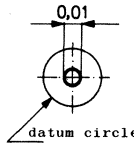
Characteristics to be tolerated	Example of indication	Interpretation	Description
Parallelism			<p>The upper axis should be contained in a cylindrical zone of diameter 0,03 parallel to the lower datum axis "A".</p>
Perpendicularity			<p>The axis of the cylinder to the dimension of which the tolerance frame is connected should be contained in a cylindrical zone of diameter 0,01 perpendicular to the datum surface "A" (datum plane).</p>
			<p>The axis of the cylinder to the dimension of which the tolerance frame is connected should be contained between two parallel straight lines 0,1 apart, perpendicular to the datum plane and lying in the plane shown on the drawing.</p>
Angularity			<p>The inclined surface should be contained between two parallel planes 0,08 apart which are inclined at 40° to the plane "A" (datum plane).</p>
Position			<p>The point of intersection should lie inside a circle of 0,3 diameter the centre of which coincides with the considered point of intersection.</p>
Concentricity			<p>The centre of the circle, to the dimension of which the tolerance frame is connected should be contained in a circle of diameter 0,01 concentric with the centre of the datum circle "A".</p>

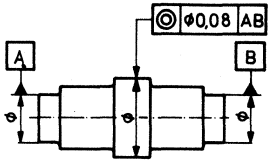
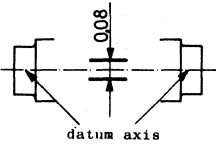
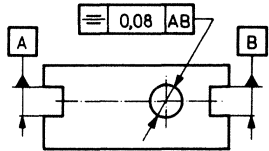
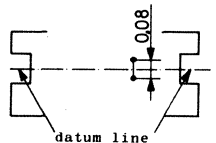
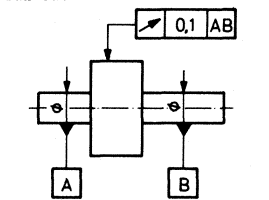
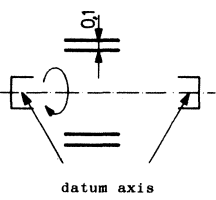
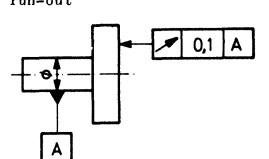
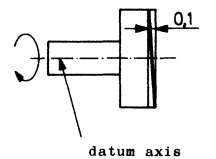
Characteristics to be tolerated	Example of indication	Interpretation	Description
Coaxiality			<p>The axis of the cylinder to the dimension of which the tolerance frame is connected should be contained in a cylindrical zone of diameter 0,08 coaxial with the datum axis "AB".</p>
Symmetry			<p>The actual axis of the hole should be contained between 2 parallel lines which are 0,08 apart and symmetrically disposed about the actual common median plane of the datum slots "A" and "B".</p>
Run-out	<p>radial run-out</p> 		<p>During one complete revolution around the datum axis "AB" radial runout should be not more than 0,1.</p>
	<p>axial run-out</p> 		<p>During one complete revolution about the datum axis "A" the axial runout should be not more than 0,1.</p>

SPECIFYING THE MAGNETIC AXIS AND DIRECTION OF MAGNETIZATION

DRAWING SYMBOLS AND TERMINOLOGY

It is recommended that the magnetic axis, or the direction of magnetization be indicated on drawings by means of the following symbols:

For the magnetic axis, or the preferred direction of magnetization in unmagnetized anisotropic magnets: the symbol $\leftarrow \underline{MA} \rightarrow$.

For the direction of magnetization in magnetized magnets: the symbol $S \rightarrow N$.

The recommended method of showing the magnetic axis or the direction(s) of magnetization is shown in the following examples:

NOTE

When ordering, please give the alphabetic designation and page date, e.g.: magnetization B, January 1981. Orientation of unmagnetized anisotropic magnets can be indicated by the prefix U, e.g.: orientation UB, January 1981. (Unmagnetized isotropic magnets: letter U.)

Magnetization for isotropic and anisotropic magnets

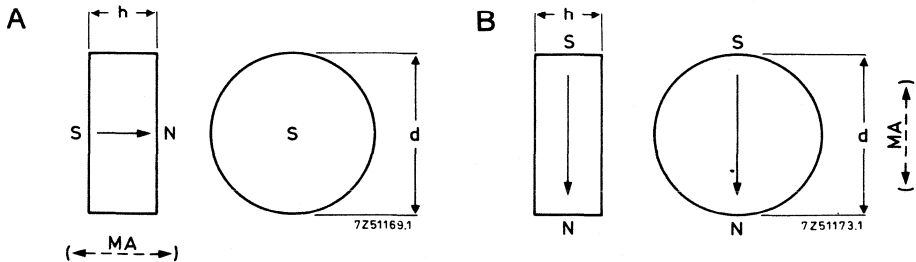

axial.*

diametrical.*

* Also to be used for rings and cylinders.

Magnetization for isotropic and anisotropic magnets (continued)

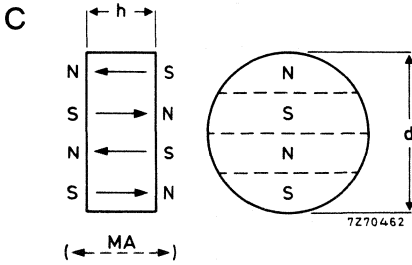

axial, n-poles,
neutral zones in parallel
(in the example $n = 4$).

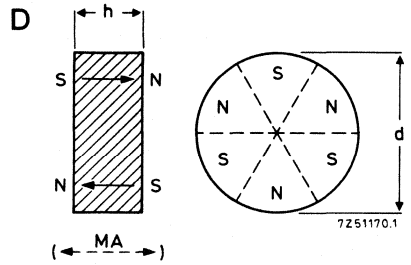

axial, n-poles,
neutral zones radial
(in the example $n = 6$).

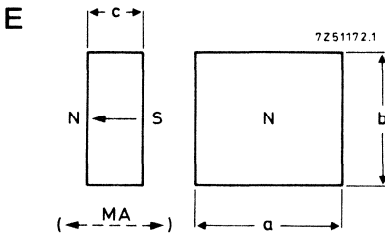

perpendicular to $a \times b$.

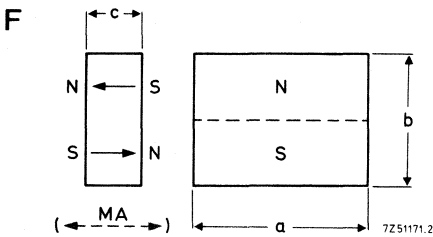

perpendicular to $a \times b$, n-poles,
neutral zone parallel to side a
(in the example $n = 2$).

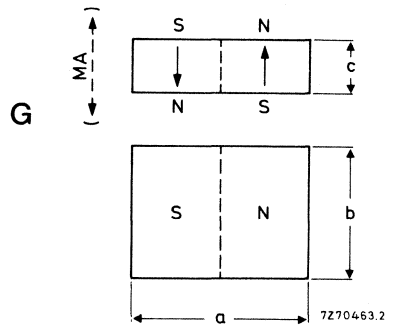

perpendicular to $a \times b$, n-poles,
neutral zone parallel to side b
(in the example $n = 2$).

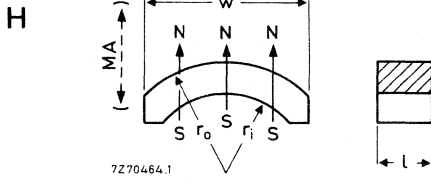

parallel (also called diametrical),
S-pole inside.

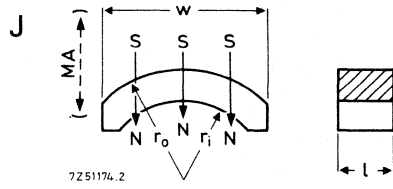

parallel (also called diametrical),
N-pole inside.

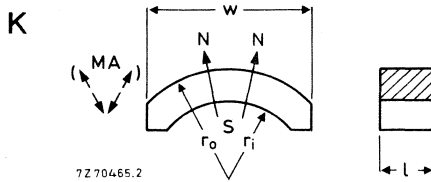

radial, S-pole inside.

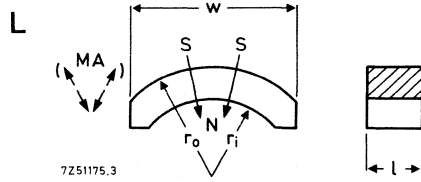

radial, N-pole inside.

Magnetization for isotropic magnets only

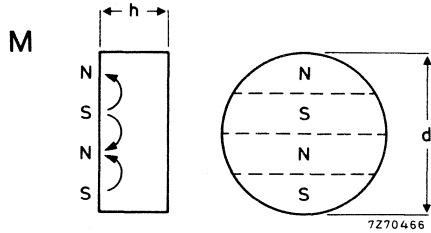

lateral, n parallel poles on one face only,
(in the example n = 4).

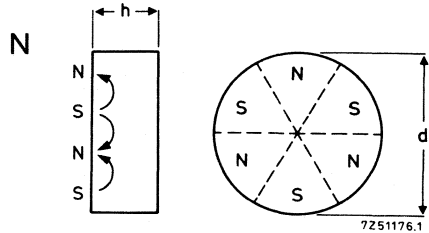

lateral, n-pole sectors on one face only,
(in the example n = 6).

NOTES

1. Multipole magnetization of K and L on both sides is possible; to be specified by user.
2. Magnetizations M and N can also be applied to both faces.
3. When magnetization M is required with an odd number of poles the polarity of the centre pole should be specified (e.g. N, S, or "don't care").

Magnetization for isotropic magnets only (continued)

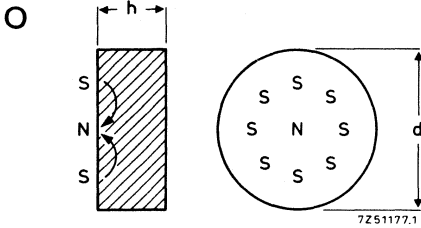

lateral, 2-poles on one face only,
centred N-pole with concentric
S-pole.

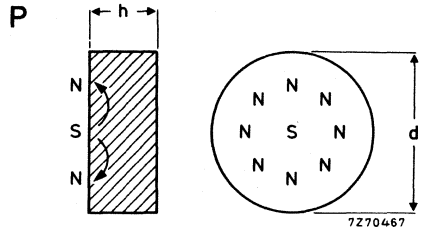

lateral, 2-poles on one face only,
centred S-pole with concentric
N-pole.

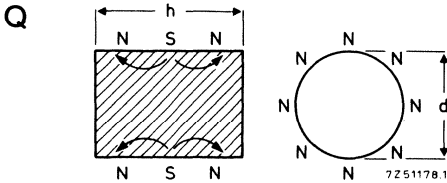

lateral, n annular poles
(in the example n = 3).

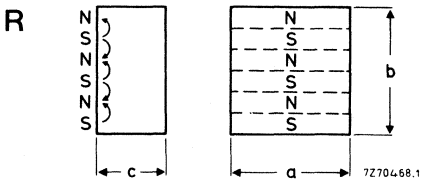
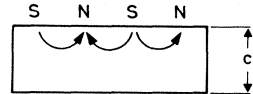

lateral, n-poles on one a x b face,
poles parallel to side a
(in the example n = 6).

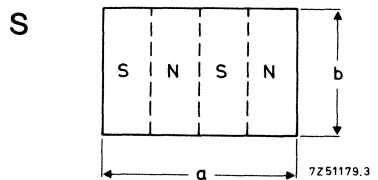

lateral, n-poles on one a x b face,
poles parallel to side b
(in the example n = 4).

NOTES

1. Magnetizations O, P, R and S can also be applied to both faces.
2. When magnetizations Q, R or S are required with an odd number of poles the polarity of the centre pole should be specified (e.g. N, S, or "don't care").

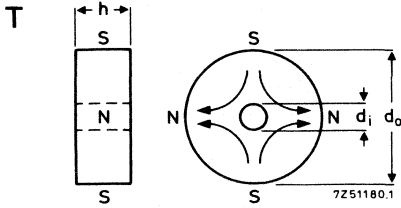

lateral, n-poles on outer circumference,
neutral zones axial
(in the example $n = 4$).

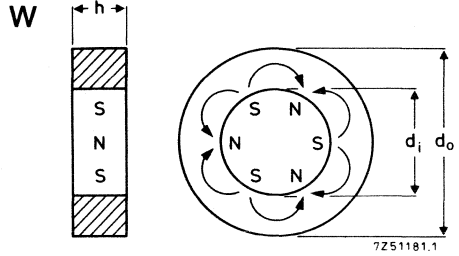

lateral, n-poles on inner circumference,
neutral zones axial
(in the example $n = 6$).

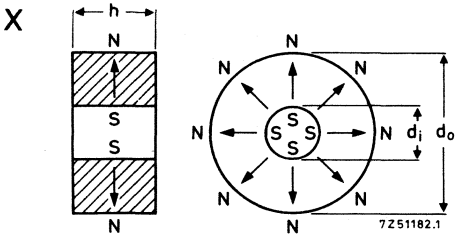

radial, S-pole inside.

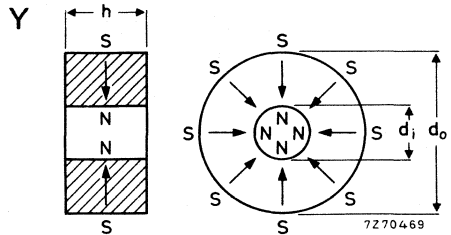

radial, N-pole inside.

U unmagnetized magnets

MARKING OF PERMANENT MAGNETS

If it is required to identify magnetized magnets of the same outline but with different directions of magnetization, a colour code is recommended.

The poles can then be marked by spots of paint or some other identification mark,

- either South pole yellow
- or North pole red
- or neutral zone white.

If it is necessary to indicate the position of poles more accurately than may be obtained by spots of paint, another method, e.g. grooves, may be used.

The method of marking, if required, should be shown on the magnet drawing.

RECOMMENDATIONS FOR MAGNETIZATION AND DEMAGNETIZATION

Magnets are usually supplied unmagnetized, and are magnetized by the user during system assembly. This simplifies handling and manufacture considerably.

Most magnets can, however, be premagnetized, but this may result in some loss, the extent depending upon the relative recoil permeability of the material. This should be determined at the working point (i.e. the point on the hysteresis loop) corresponding to the highest demagnetizing field experienced by the magnet before assembly. For a magnet working under open-circuit conditions, the area in the middle of the pole-faces normally experiences a higher demagnetizing effect than the periphery. The working point under these conditions is determined by the size and shape of the magnet. In computing these losses, the minimum values for the characteristics at the lowest storage temperature should be assumed. For most currently used shapes, the expected losses (computed values) are available from us on request.

Note: some Ferroxdure and rare-earth cobalt materials have relative recoil permeabilities close to unity through a substantial part of the second quadrant of their hysteresis characteristics. Such materials show little loss when premagnetized.

MAGNETIZATION

A magnet is magnetized instantaneously by exposing it to an external unidirectional field, produced by a permanent magnet or, more usually, by a direct current (or pulsed current) flowing through a coil. The magnetizing field must not be less than the saturation field H_{sat} for the material, otherwise the full properties will not be obtained.

In some systems the requirement is not clear, for example the magnet may be shielded by other magnetic material which then must also be saturated. In practice the magnetizing field should be increased until no further increase in magnet flux can be measured. For magnetizers using steel poles, saturation of the equipment could occur before the magnets are fully saturated. An alternative can be to use ironless coils correctly positioned. Advice where required should be sought.

The required magnetizing current can be obtained from many alternative d.c. sources. Apart from obtaining the correct magnetizing field strength, the choice will depend on possible size of coil, temperature rise of conductors, repetition rate and other production circumstances. Where heat dissipation can be a problem with small coils, pulsed currents derived from discharging capacitors or other current sources is a solution. There are suppliers of power supplies for magnetizing equipment.

After magnetizing it is possible to equalize the performance of magnetic systems by partial demagnetization of the magnets. This can be done by applying an increasing d.c. field in the reverse direction until the magnetization falls to the required level, the field preferably being controlled by some means with the facility to measure the instantaneous magnetic flux density.

DEMAGNETIZATION

Modern magnetic materials have a high resistance to demagnetization, and complete demagnetization is usually difficult if not impossible. Sintered Ferroxdure magnets are best demagnetized by heating them above their Curie point (about 450 °C). Bonded or metal magnets need a magnetic field to demagnetize them, usually a gradually diminishing a.c. field whose initial value is great enough to force the magnet through its hysteresis cycle. For larger magnets, complete demagnetization is usually impossible.

INSPECTING PERMANENT MAGNETS

Permanent magnets are usually inspected for mechanical and magnetic properties and appearance. Mechanical inspection follows normal procedures, as does visual inspection. Magnetic inspection is best carried out by checking the performance under conditions which approximate as closely as possible the working conditions for which the magnet is intended. For this reason the inspection procedure of any type of magnet should be laid down in consultation with the customer. A simplified model of the magnetic circuit will often suffice for measuring flux, voltage, force of attraction, etc., according to the application.

VISUAL INSPECTION

The visual standards required are set by means of limit samples, photographs of which have been made. For each visual characteristic there should be two limit samples, one of which is the "worst acceptable" sample and marked "O", and the other, the "test reject" sample and marked "X". For most products, the photographs are already available.

MAGNETIC INSPECTION

Full determination of the magnetic properties of each magnet is too expensive for mass-production inspection. It has, therefore, become normal practice to perform comparison tests against a "minimum standard magnet", copies of which are supplied on request.

The minimum standard may have either
 minimum remanence (B_r), a "minimum flux standard",
 or minimum coercivity (H_{cB}), a "minimum coercivity standard".

These magnets will have the following dimensions:

- Blocks, segments and axially magnetized cylinders, discs and rings
 perpendicular to M.A.
 parallel to M.A.
- Diametrically magnetized cylinders and discs
- Diametrically magnetized rings

bottom limit dimensions
 mid-limit (nominal)

bottom limit diameter and
 height

bottom limit diameter,
 wall thickness and height

AQL SYSTEM

The quality of our permanent magnets is guaranteed in conformity with MIL-STD-105D. The AQL values are laid down as follows:

Attributes	AQL	Inspection level
Visual	0,65%	II
Dimensional	0,65%	II
Magnetic	0,65%	II

For the attributes reference is made to the magnet specification concerned.

DESIGN ADVISORY SERVICE

Our application engineers offer technical assistance on the use and design of permanent magnets and complete permanent-magnet systems. Guidance is also offered on ancillary problems such as installation, handling and magnetization. If you require more specific information than is provided here please send your enquiry to us.

Orders for new magnet shapes can be dealt with more easily if they are accompanied by the following information:

- (1) The purpose for which the magnet is to be used.
- (2) A sketch or drawing of the magnet showing its shape and dimensions, with tolerances.
- (3) The direction of the magnetic axis or the arrangement of poles.
- (4) Surfaces to be ground and shape tolerances.
- (5) The material of the magnet.
- (6) Whether the magnet is to be supplied magnetized or unmagnetized.
- (7) The quantity required and the desired rate of delivery.

COMPUTER-AIDED DESIGN SERVICE

Traditional empirical and graphical permanent-magnet design methods are often laborious and, particularly for dynamic or complex systems, seldom result in a design whose performance is magnetically or economically optimum. Computer-aided design, due to the ability to perform iterative calculations quickly, can prove almost ideal for permanent-magnet systems. During the past ten years programs have been developed both for specific design problems such as loudspeakers and motors and for the detailed analysis of magnetic circuits. Based upon these programs, and backed by many years accumulated experience, it is now possible to provide users of our magnetic materials with a comprehensive design service.

THE MAGGY PROGRAM

The MAGGY program uses a mathematical expression of the permanent magnet as the basis for the computer analysis of two-dimensional magnetic systems. It is thus suitable for fundamental design analysis of rotationally-symmetrical magnet assemblies, such as loudspeaker units, Fig. 1; or assemblies which are long compared to the air gaps in the circuit, such as motors, Fig. 2. As these two plots generated by the MAGGY program show, the output is in the form of plots of equi-flux lines superimposed on a section through the assembly under analysis. The plot is supplemented by a print-out of flux densities over the system and surrounding space.

MAGGY is mainly used for the investigation of new magnetic arrangements or materials, such as the low-stray field loudspeaker design shown in Fig. 5. Using the information obtained from MAGGY, supplemented by extensive practical experience, programs have been developed for the design of systems for two of the main areas of magnet applications: loudspeakers and motors.

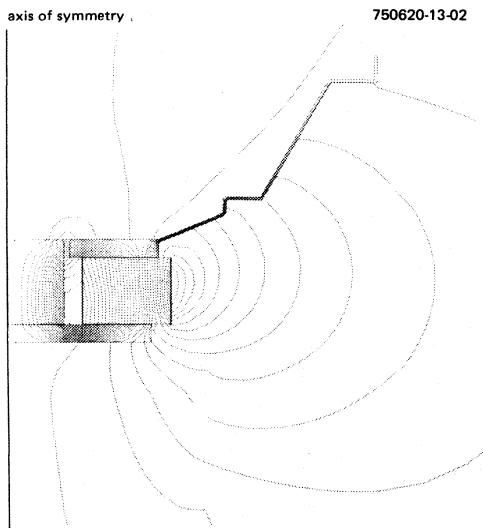

Fig. 1.

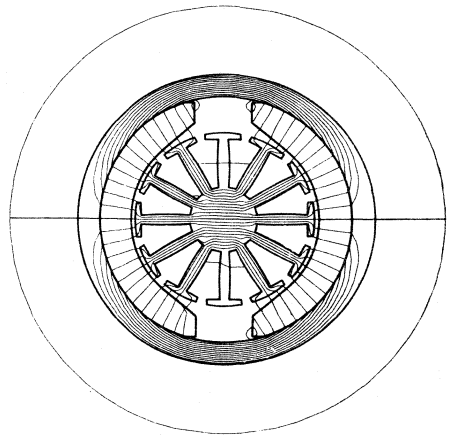

Fig. 2.

LOUDSPEAKER DESIGN

For the computer-aided design (CAD) of conventional loudspeaker motor unit magnets using Ferroxdure ring magnets, a dedicated program is available. This optimizes the design of a magnet system for minimum use of both hard and soft magnetic materials, subject to engineering limitations. The effect of ambient temperature range is taken into account.

Figure 3 and the table give the input data required for the design of a loudspeaker system using this program.

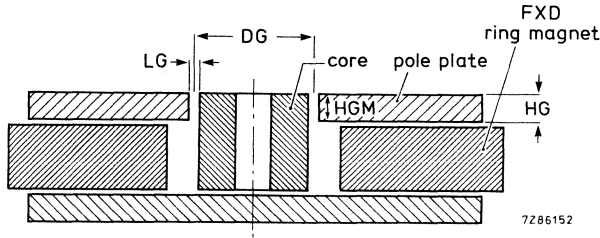

Fig. 3.

Input data for loudspeaker-design program

Air gap:	diameter	DG = m
	length	LG = m
	height	HG = m
	field measurement height	HGM = m
	induction over HGM	= T
	or flux over HGM	= Wb
General:	ambient temperature	TA = K
	cold stability	KS = K
	permissible flux loss	
	after operation at KS	= %
Stray flux requirement:		
Other requirements:		

Where a design of loudspeaker that generates minimum stray field is required, for such applications as colour TV receivers, the traditional solution to the problem has been to use a totally-enclosed design based on a slug of metal-alloy permanent-magnet material such as Ticonal. The increasing cost of the raw materials for these alloys has made the use of screened or compensated designs based on Ferroxdure materials more attractive.

The plot of Fig. 1. shows the stray field generated by a conventional ring-magnet design, as plotted by means of MAGGY. The similar plots of Figs 4 and 5 show the reduction in stray field obtained by screening and the use of a compensating magnet. Both design problems would be extremely difficult to solve except by means of CAD.

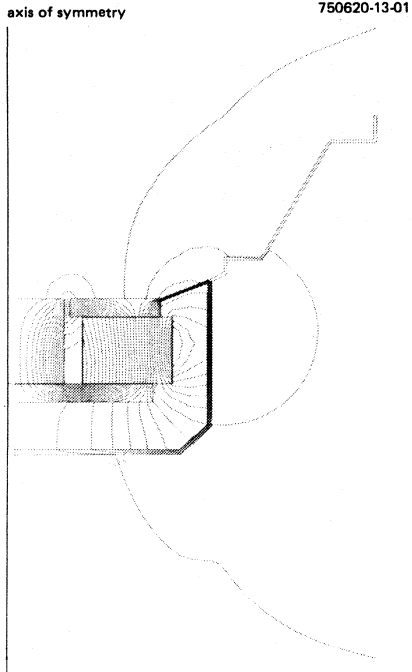

Fig. 4.

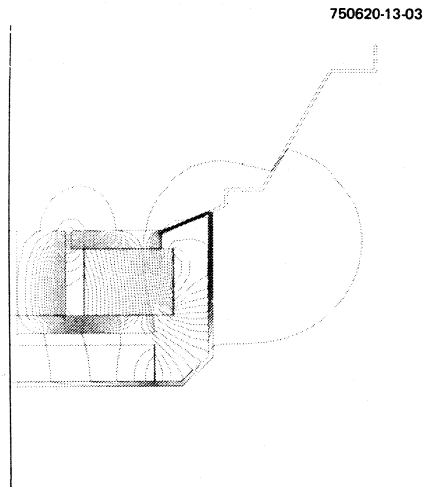

Fig. 5.

PERMANENT-MAGNET MOTOR DESIGN

The majority of permanent-magnet motors use anisotropic ferrite segments in the arrangement shown in Fig. 6. The magnets in such a system are subjected to varying demagnetizing forces according to the current flowing in the motor armature, which is greatest under stall or starting conditions. Moreover, the effect of these demagnetizing influences depends on the operating temperature of the permanent magnets themselves. These and other design factors are fully discussed in the Reference.*

Our dedicated motor-design program is capable of producing motor designs for minimum cost or weight and to a particular fixed dimension, such as length or diameter, for a particular application. Given the required motor parameters, with the aid of the program a design can be produced to satisfy a specific requirement. The necessary input data are:

LOAD

operating speed N_1 = (r.p.m.)
operating torque at N_1 r.p.m. = (Nm)
mechanical efficiency at N_1 r.p.m. = (%)

and, if possible, a second point of the motor characteristic such as
stall torque = (Nm)

or

maximum output power = (W)
armature speed for maximum output power = (r.p.m.)

AMBIENT CONDITIONS

ambient temperature T_1 = ($^{\circ}\text{C}$)
minimum temperature T_2 = ($^{\circ}\text{C}$)

ELECTRICAL CIRCUIT

electromotive force of the power supply at T_1 = (V)
internal resistance of the power supply at T_1 = (Ω)
internal resistance of the power supply at T_2 = (Ω)
series resistor at T_1 = (Ω)
voltage drop across the brushes or the brush resistance = (Ω)
if the supplied voltage is an a.c. voltage the type of rectification (bridge, SMPS etc)
supply frequency = (Hz)
fast current limit yes/no

if yes:

maximum current = (A)

OTHER REQUIREMENTS

e.g. transmission ratio of a gearbox, efficiency of the gearbox etc.

* Reference: Heffen, H.J.H. van, 1980. Ceramic permanent magnets for d.c. motors. Electronic Components and Applications 3, 22-30 and 120-125 (Vols 1 and 2).

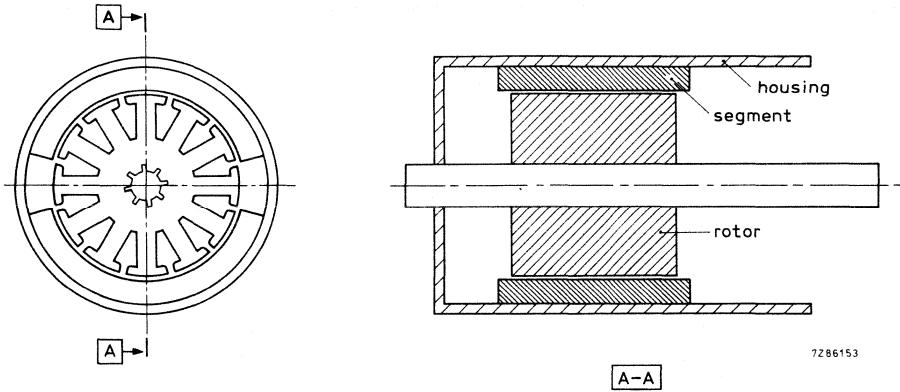

7286153

Fig. 6.

If required one or more of the following motor data can be fixed:

HOUSING:	outside diameter	= (mm)
	wall thickness	= (mm)
	saturation flux density	= (gauss)
MAGNET:	permanent magnet material	=
	outside radius	= (mm)
	inside radius	= (mm)
	thickness	= (mm)
	length	= (mm)
	angle	= (deg)
ROTOR:	shape of the segment feet	basic/radial
	diameter	= (mm)
	saturation flux density	= (gauss)
	loss factor of the rotor iron	= (W/kg)
	lamination thickness	= (mm)
	number of slots	=
	shape of the slots	parallel teeth/parallel slot
WINDING:	width of the tooth	= (mm)
	shaft diameter	= (mm)
	rotor winding	lap/wave
	slot span	=
OTHER:	number of commutator bars	=
	length of the air gap	= (mm)
	number of pole pairs	=
	pairs of parallel paths	=
	maximum fill factor of the slot	=
	maximum current density at the operating speed	= (A/mm ²)
	maximum rotor dissipation at the operating speed	= (W/cm ²)

GENERAL

Given this information, and depending on the optimization criteria (cost, weight, efficiency etc.), the program generates a recommended design in the following format:

HOUSING	outside diameter	=	mm
	inside diameter	=	mm
	thickness	=	mm
	length (min)	=	mm
	induction	=	gauss
SEGMENT	weight	=	g
	material	=	
	min. outside radius	=	mm
	inside radius	=	mm
	thickness + air gap	=	mm
	thickness	=	mm
	height	=	mm
	width	=	mm
	length	=	mm
	angle	=	deg
ROTOR:	total weight	=	g
	diameter	=	mm
	length (iron)	=	mm
	rotor material	=	
	stamping thickness	=	mm
	number of slots	=	
	width of slot bottom	=	mm
	width of slot top	=	mm
	depth of slot	=	mm
	slot area	=	mm ²
	tooth width	=	mm
	weight	=	g
WINDING	wire diameter	=	mm
	conductors per slot	=	
	number of conductors	=	
	turns per coil	=	
	winding angle	=	deg
	weight	=	g
OTHER DATA	overhang (LR/LM)	=	
	air gap length	=	mm
	number of polepairs	=	
	pairs of par. paths	=	
	ambient temperature	=	deg
	cold stability	=	deg
	rotor induction	=	g
	induction rotor core	=	g
	fill factor	=	
	current density	=	A/mm ²
	rotor dissipation	=	W/cm ²
	copper losses	=	W
	iron losses	=	W
	armature reaction	=	A/cm
allowed backfield	=	A/cm	
total weight	=	g	

MULTI-GRADE MOTOR SEGMENTS

The MAGGY plot of Fig. 7 shows how, when the armature is energized, the permanent magnet segments in a motor are subject to demagnetizing forces that vary over their circumference. In this plot, where the flux density is minimum the demagnetization is maximum.

A double-injection pressing technique for motor segments is available that allows an extra-high coercivity grade of Ferroxdure to be substituted for the standard grade in that part of the segment where demagnetization is greatest. This improves motor performance, especially efficiency, for a given motor diameter. Our CAD facilities enable us to optimize the design of such multi-grade segments for a specific application.

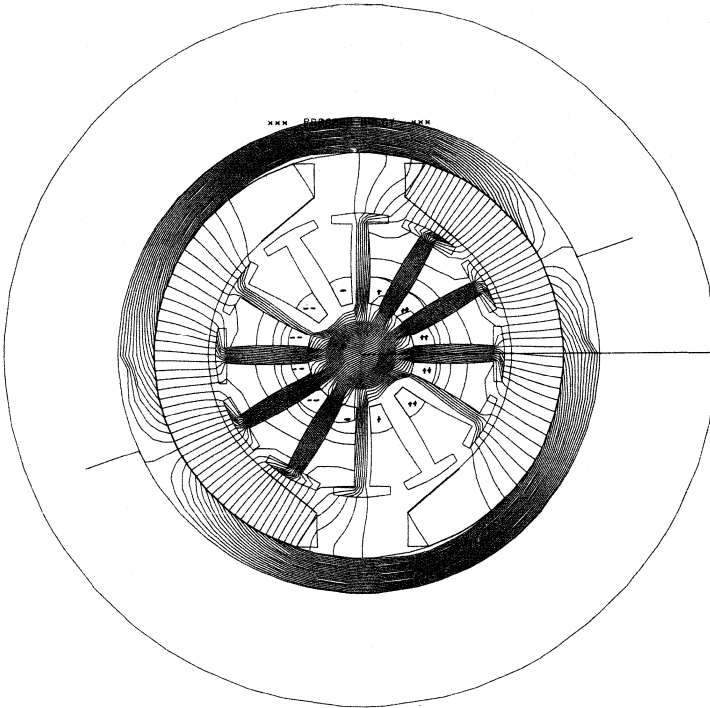

Fig. 7.

APPLICATIONS OF PERMANENT MAGNETS

CLASSIFICATION ACCORDING TO MAGNETIC FUNCTION

As a rule, permanent magnets function as energy transducers which convert energy from one kind into another, without permanently losing energy of their own. In keeping with this, permanent magnets may be classified as follows.

For the conversion of:

- electrical energy into mechanical
such as in motors, meters, loudspeakers, beam deflectors, mass spectrometers;
- mechanical energy into electrical
such as in generators, alternators, cycle dynamos, microphones, phonographic pick-ups, electric stringed instruments, magnetic detectors;
- mechanical energy into other mechanical energy
such as for attraction and repulsion, holding and lifting (e.g. in industrial and household appliances, separators, chucks, thermostats, toys, etc.);
- mechanical energy into heat
such as in hysteresis-torque and eddy-current instruments, e.g. speedometers, brakes of watt-hour meters, balances, etc.

Permanent magnets may also be used to accomplish special effects such as:

- Hall effect,
- magnetic resistance,
- nuclear magnetic resonance.

APPLICATION EXAMPLE

Loudspeaker systems using Ferroxdure rings

Figure 1 shows a relatively simple loudspeaker magnet system equipped with a Ferroxdure ring magnet. The arrangement illustrated provides high air gap flux densities and is able to take full advantage of the high coercivity of Ferroxdure, allowing flat and compact designs to be realized. Such systems can usually be analysed empirically. Below we illustrate how this can be done. The method described lends itself particularly well to analysis using small computers or programmable calculators.

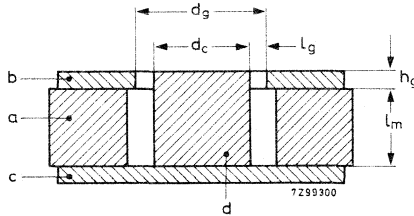

Fig. 1.

The system consists of:

- (a) axially magnetized Ferroxdure ring;
- (b) soft-iron ring serving as top pole plate;
- (c) soft-iron disc serving as bottom pole plate;
- (d) soft-iron cylindrical core.

The soft iron is of the free-cutting steel type.

Loudspeaker magnet systems can be characterized by:

$$d_c/h_g/B_g - l_g,$$

where: d_c = core diameter in mm;

h_g = height of air gap in mm;

B_g = flux density (induction) in the air gap in Gs ($= 10^{-4}$ T)

l_g = width of air gap $= (d_g - d_c)/2$, in mm.

The pole plates b and c have a smaller outside diameter than the magnet ring a. A magnet overhang of 1 to 1,5 x dimension h_g is recommended since this will result in an optimum ratio of leakage to useful flux.

System design

We start by assuming that the iron parts of the system are unsaturated (this should be a prerequisite of the design, otherwise useful flux will be lost). The flux in the iron poles ϕ_{ST} can then be taken as the mean of the magnet flux ϕ_m and the air gap flux ϕ_g .

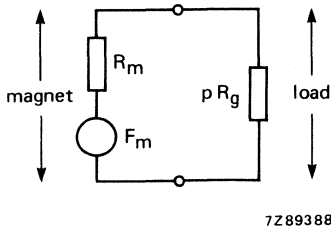

7Z89388

Fig. 2 Equivalent magnetic circuit.

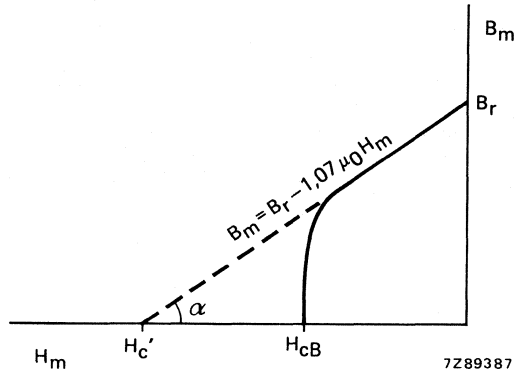

7Z89387

Fig. 3 Demagnetization curve of Ferroxdure.

Figure 2 shows the magnet equivalent circuit, the magnet being represented by an internal resistance (reluctance) R_m in series with a magnetomotive force F_m . We assume a linear demagnetization characteristic. This is shown in Fig. 3 and for Ferroxdure can be expressed as:

$$B_m = B_R - 1,07 \mu_0 H_m \tag{1}$$

in which H_m is the field strength of the magnet at some working point, B_R its remanence, B_m the magnetic flux density and μ_0 the permeability of free space. If the linear region of the characteristic is projected back, it intersects the H axis at $H_{c'}$, a value higher than the magnet's coercivity H_{cB} . So for a magnet of length L_m , $F_m = H_{c'} L_m$.

Although eq. (1) is not valid for the complete demagnetization characteristic, it does describe the relationship between B_m and H_m over the region of interest. Its validity is in fact limited to the reversible region of H_m , i.e. the region within which the value of B_m returns to B_R whenever H_m returns to zero.

Calculation of air-gap flux-density

If $B_m = 0$, then from Fig. 3 and eq. (1), $H_{c'} = H_m = B_R / 1,07 \mu_0$. Therefore:

$$F_m = L_m B_R / 1,07 \mu_0 \tag{2}$$

From the equivalent circuit of Fig. 2, the magnet reluctance $R_m = F_m / B_R A_m$, where A_m is the cross-sectional area of the Ferroxdure ring. Therefore:

$$R_m = L_m / 1,07 \mu_0 A_m \tag{3}$$

The magnet's external load will include leakage paths as well as the intended air gap. For magnet systems like the one shown in Fig. 1, it has been found empirically that the useful air-gap flux

$$\phi_g = F_m / (\rho R_g + R_m) \tag{4}$$

in which R_g is the reluctance of the useful air gap and $\rho = 27,5 \mu_0 L_m R_m + 1,55$. For an air gap of length L_g and area A_g :

$$R_g = L_g / \mu_0 A_g \tag{5}$$

Combining eqs (2) and (5):

$$\phi_g = \frac{L_m B_R / 1,07 \mu_0}{(L_g / \mu_0 A_g) (27,5 \mu_0 L_m R_m + 1,55) + L_m / 1,07 \mu_0 A_m} \quad (6)$$

The effective air-gap flux density is then:

$$B_g = \phi_g / A_g$$

with $A_g = \frac{1}{2} \pi (d_c + d_g) h_g = \pi (d_c + L_g) h_g$

Finding the magnet working point

Stable operation of the magnet over its specified operating temperature range can only be assured if the magnet operates at a suitable working point. For magnet systems of the type shown in Fig. 1, it has been found empirically that the total magnet flux

$$\phi_m = F_m / (R_m + R_g / \rho') \quad (7)$$

where $\rho' = 8,5 \mu_0 L_m R_m + 1,65$

The average magnetic induction $B_m = \phi_m / A_m$. Therefore combining eqs (2), (3) and (7):

$$B_m = D B_R$$

where

$$D = \frac{L_m / 1,07 \mu_0}{L_m / 1,07 \mu_0 A_m + (L_g / \mu_0 A_g) / (8,5 \mu_0 L_m R_m + 1,65)}$$

and from eq. (1):

$$H_m = (1 - D) B_R / 1,07 \mu_0.$$

The magnet working point (H_m , B_m) at a given temperature can therefore be found as a function of its remanence B_R at that temperature. However, it is far more convenient to express the working point in terms of the remanence at ambient temperature (25 °C), since this is the value quoted in our data sheets. Now the induction of a magnet at temperature T is related to its ambient value $B(T_a)$ by:

$$B(T) = B(T_a) \left\{ 1 + \alpha_B / 100 (T_a - T) \right\}$$

where α_B is the temperature coefficient of remanence. Note: this is a negative quantity which means that remanence increases with falling temperature. The working point at temperature T is then given by:

$$B_m(T) = D B_R(T_a) \left\{ 1 + \alpha_B / 100 (T_a - T) \right\} \quad (8)$$

and

$$H_m(T) = (1 - D) B_R(T_a) / 1,07 \mu_0 \left\{ 1 + \alpha_B / 100 (T_a - T) \right\} \quad (9)$$

Low temperature stability

The coercivity of a magnet varies with temperature according to the relation:

$$H_{CJ}(T) = H_{CJ}(T_a) \left\{ 1 + \alpha_H / 100 (T_a - T) \right\} \quad (10)$$

in which α_H is the temperature coefficient of coercivity. As the magnet gets colder, H_{CJ} approaches H_m and the magnet working point gets closer to the knee of the demagnetization curve. At a certain temperature, T_{min} , the working point will be located precisely on the knee of the curve. Beyond this point, which can be assumed to occur at $H_m(T_{min}) = 0,83 H_{CJ}(T_{min})$ for FXD300, the magnet will almost certainly experience some demagnetization. Permanent loss of flux will therefore occur at temperatures below T_{min} .

Combining eqs (9) and (10), we arrive at the following expression for T_{\min} (for FXD300):

$$T_{\min} = T_a - \frac{0,83 H_{CJ}(T_a) - (1 - D)B_R(T_a)/1,07 \mu_0}{0,83 \alpha_H H_{CJ}(T_a)/100 - \alpha_B B_R(T_a)/1,07 \mu_0} \quad (11)$$

Minimizing magnet volume

The design of a new loudspeaker magnet-system should seek to minimize magnet volume in order to make the most economic use of the magnetic material. Below we show how the minimum magnet volume can be calculated for a given air-gap size and flux-density.

From eq. (6), magnet volume V_m is given by:

$$V_m = A_m L_m = \frac{\phi_g(L_m^2 + 27,5 \mu_0 R_g L_m^3)}{(L_m B_R - 1,66 \mu_0 R_g \phi_g)} \quad (12)$$

Differentiation of this expression with respect to L_m and equating to zero gives the condition for minimum magnetic volume, viz:

$$\frac{55 L_m^2 B_R}{1,07} + \left\{ \frac{B_R}{1,07 \mu_0 R_g} - 128 \mu_0 R_g \phi_g \right\} L_m - 3,1 \phi_g = 0 \quad (13)$$

The positive root of this quadratic equation gives the value of L_m for minimum magnet volume. Substitution of this value into eq. (12) gives the magnet area A_m .

The value of L_m found from solving eq. (13) may be too small to allow the required coil movement in the final magnet system. L_m must then be increased and a new value of A_m calculated from eq. (12). In this case, of course, the magnet volume will no longer be minimized.

The newly designed system should be analysed to check its low temperature stability using the method described in the foregoing section. Should the magnet prove to be unstable at its working point, this again will necessitate an increase in L_m .

Note: it is normally possible to select a standard magnet from our range having dimensions sufficiently close to the calculated values.

FERROXDURE

FERROXDURE

INTRODUCTION

The largest volume production of industrial permanent magnet materials is in the ferro-magnetic oxides, one of which is the ceramic material known as Ferroxdure.

Ferroxdure, a ceramic material containing only non-critical raw materials, is distinguished by its high coercivity – up to about 400 kA/m – and such high electrical resistivity that it may be considered an insulator.

The high coercivity permits magnets of short magnetic lengths to be used without excessive self-demagnetization. The high electrical resistivity – some 10^{10} times that of iron – minimizes eddy current losses and thus makes Ferroxdure an ideal material for high frequency applications.

Ferroxdure corresponds approximately to the chemical formula $(M)Fe_{12}O_{19}$ where M stands for Ba, Sr, Pb etc.

Ferroxdure being a true ceramic material is hard and brittle, and close dimensional tolerances can only be achieved by grinding.

Anisotropic sintered Ferroxdure permanent magnets are manufactured by mixing the raw materials in the correct ratio. The mixture is granulated and pre-fired. The pre-fired granules are wet-milled to a very fine powder suspension. The powder suspension – or slurry – is then moulded to the required shape by high pressure compaction in dies with simultaneous application of an intense homogeneous magnetic field. The pieces are now magnetically oriented. After this magnetic treatment, the oriented compacted pieces are again fired in the furnace in which atmosphere and temperature are accurately controlled, and emerge with a ceramic structure.

Compared with isotropic Ferroxdure, the oriented or anisotropic Ferroxdure permanent magnets possess a very much improved performance in the direction of the magnetic field used during pressing.

Note: During sintering, the magnets shrink by about 15% (compared with the size of the pressed form).

INTRODUCTION (continued)

Plastic-bonded Ferroxdure, isotropic and anisotropic permanent magnets are manufactured from a mixture of Ferroxdure powder (dried slurry) with either thermoplastic or thermosetting materials as bonding agents. Familiar plastics-manufacturing techniques such as extrusion, injection moulding and pressing are used for the shaping of the magnets.

The plastic-bonded Ferroxdure materials combine the magnetic properties of sintered Ferroxdure (but at a lower level) with the mechanical advantages of plastics. They can be used to make magnets which

- can be bent and even cut with a knife or scissors (P-grades);
- meet fine size tolerances without being machined (SP grade);
- have complicated shapes (all grades);
- can be machined with conventional tools (all grades);
- can possess inserted metal parts, such as shafts, plates and bushes (SP grade).

Thus, plastic-bonded Ferroxdure magnets can be used in applications from which permanent magnets were formerly excluded (for technical or economic reasons).

MATERIAL GRADES

Isotropic plastic-bonded Ferroxdure

Ferroxdure SP10 and SP50

Relatively rigid;
shaped by injection moulding.

Ferroxdure P30 and P40B

Soft, flexible and resilient;
shaped by extrusion or injection moulding.

Anisotropic plastic-bonded Ferroxdure

Ferroxdure SP130, SP170

Relatively rigid;
shaped by injection moulding.

Anisotropic sintered Ferroxdure

Ferroxdure 270, 330, 380, 400, 460, 480, 500, 520 and 580

The materials have high values of coercivity, and are therefore ideal for dynamic applications where strong demagnetizing influences are encountered, for example in radially oriented segments for use in d.c. motors. Segments are also available which combine two different materials (normally a high remanence and a high coercivity material).

Ferroxdure 300

This material is especially well suited to static applications when a high coercive force is not necessary. If the magnet is likely to be removed from its system, and/or if it is likely to be subjected to high flux, it should preferably be magnetized within its system.

CHEMICAL RESISTANCE

Sintered Ferroxdure is not attacked by:

- sodium chloride solutions, up to 30% concentration
- benzol and trichloroethylene solutions, up to 50% concentration
- petrol
- nitric acid, up to 50% concentration
- acetic acid
- creosol
- phenolic solutions
- sodium sulphate solutions.

It is slightly attacked by diluted sulphuric acid and by a solution of hydrochrotic acid, 50% concentration. It is attacked by concentrated hydrochloric acid.

Plastic-bonded Ferroxdure: see Material specifications.

FIXING SINTERED FERROXDURE MAGNETS

Sintered Ferroxdure magnets are normally fixed to other magnets by means of adhesives. Holes are difficult to incorporate. When selecting adhesives for fixing Ferroxdure magnets to metal components, such as pole pieces, it should be noted that the coefficient of linear expansion of sintered Ferroxdure is considerably smaller than that of most metals:

Sintered Ferroxdure	$8 \text{ to } 15 \cdot 10^{-6}/\text{K}$
Steel	$11 \text{ to } 20 \cdot 10^{-6}/\text{K}$
Brass	$18 \cdot 10^{-6}/\text{K}$

TEMPERATURE COEFFICIENTS

All grades of Ferroxdure have a negative temperature coefficient of remanence of about 0,2%/K and a positive temperature coefficient of coercivity of about 0,8 kA/m/K for Ba-ferrite and 0,95 kA/m/K for Sr-ferrite. For isotropic Ferroxdure, the effect of temperature on magnetic performance is reversible, i.e. after heating or cooling, the magnet will return to the point on the BH curve at which it started. Permanent demagnetization only occurs if the magnet is heated to a temperature above the Curie point.

When anisotropic Ferroxdure magnets are cooled, care should be taken to ensure that, at the lowest temperature, the working point is not below the knee of the demagnetization curve. If this happens, there will be a permanent loss of flux. This is because the published demagnetization curves are for materials at 25 °C; at other temperatures the magnetization curves will be different, Fig. 1.

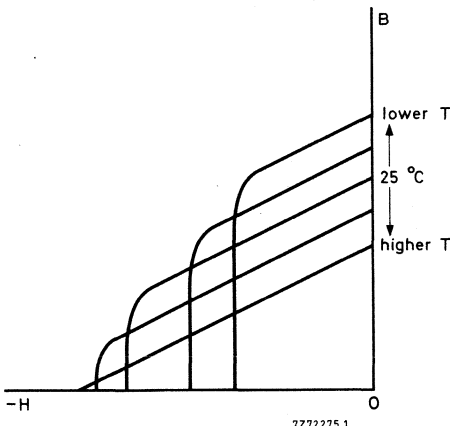

Fig. 1.

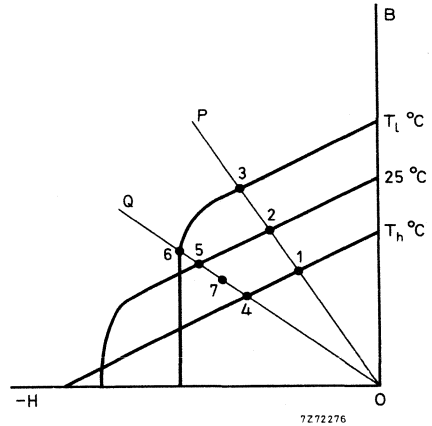

Fig. 2.

The working point on the demagnetization curve is determined by the slope of the "working line" (see Theory of Permanent Magnets section). As can be seen in Fig. 2, if the working line is OP, the working point is 2 at 25 °C, 1 at some higher temperature and 3 at some lower temperature. Since all three working points are on the upper straight line part of the demagnetization curve, the working point will return to point 2 after cycling.

If the working line is OQ, then, despite the fact that the working point is above the knee (point 5) at 25 °C and at higher temperatures (point 4), it will go below the knee if the temperature falls sufficiently (point 6). If after cooling to T_l , the temperature is raised to 25 °C, the working point will not return to point 5 but will recoil to point 7. The level of flux in the magnet will be permanently reduced.

The following expression defines the flux (B_{25}) remaining in the magnet after it has been cooled to T_{ℓ} °C and warmed to 25 °C:

$$B_{25} = \frac{B_{\ell}}{1,0475 - 0,0019 T_{\ell}}$$

In this expression, B_{ℓ} is the flux density at T_{ℓ} °C. To find B_{ℓ} , plot the demagnetization curve of the material for a temperature of T_{ℓ} °C, and draw the working line for the magnet. Note: in plotting the demagnetization curves for temperatures other than 25 °C, the new values of B_r and H_{CB} can be calculated from the temperature coefficients given in the material specification, and the curves from B_r and H_{CB} plotted parallel to the 25 °C curve until they intersect. The point of intersection indicates the position of the new knee.

For high temperature operation, the working line should intersect the demagnetization line above the knee at room temperature; thus, it will then continue to do so as the temperature rises. Flux changes (due to temperature cycling) will then be reversible.

The upper temperature limit is the "maximum permissible temperature" (plastic-bonded Ferroxdure) or the Curie point (sintered Ferroxdure), as given in the material specifications.

FERROXDURE P30

isotropic plastic-bonded ceramic material

GENERAL

This specification relates to tests carried out on test pieces made from each batch of material taken from normal production. The test piece is an extruded strip with a cross-section of approximately 11 mm x 3 mm.

Magnets manufactured from this material conform generally to this specification but, owing to the method of manufacture and to the variation in size and shape, some limits cannot always be realized, or indeed checked by measurement on the magnet. However, a minimum-flux test or similar test described in each magnet specification, can be used as a basis for performance guarantees.

COMPOSITION

Ferroxdure P30 is a barium ferrite, the main constituent being BaFe₁₂O₁₉ with 15% (by weight) of thermoplastic material added.

MAGNETIC AND ELECTRICAL PROPERTIES OF THE TEST PIECE

Temperature of the test piece is 25 ± 2 °C unless otherwise specified.

		typ.	min.	typ.	min.
Remanence	B _r	125	115 mT	1250	1150 Gs
Coercivity	H _{cB}	88	84 kA/m	1110	1050 Oe
Polarization coercivity	H _{cJ}	190	kA/m	2390	Oe
Maximum BH product	(BH) _{max}	2,8	2,4 kJ/m ³	0,35	0,3 MGsOe
Temperature coefficient of B _r (-20 to +90 °C)		-1,2	%/K	-0,2	%/°C
Saturation field strength	H _{sat}	800	kA/m	10 000	Oe
Resistivity	ρ		10 ⁷ Ωm		10 ⁹ Ωcm

After storage of the magnetized test piece for 48 h at -30 °C and 48 h at +90 °C the changes in its magnetic properties do not exceed ± 3% of the initial values.

PHYSICAL PROPERTIES

Density	typ.	3,1 x 10 ³ kg/m ³ (3,1 g/cm ³)
Maximum temperature range (continuous)		-50 to +90 °C
Flame retardance of P30		to UL 94-HB

PHYSICAL PROPERTIES (continued)

Typical values at ambient temperature after
100 h storage at:

	-50 ± 2 °C	25 ± 2 °C	70 ± 2 °C
Shore C hardness after 10 s	55 ± 10	55 ± 10	70 ± 10
Tensile strength at uniform speed of 50 mm/min	200	200	250 N/cm ²
Diameter of mandrel around which the test piece can be bent without cracking or breaking; broad face in contact with mandrel	10	10	15 mm
Linear shrinkage	0,25	0,25	2 %

CHEMICAL RESISTANCE

	25 °C		70 °C	
	up to 5 h	life test	up to 5 h	life test
Water	+	+	+	+
Thinned acids	+	-	+	-
Concentrated acids	-	-	-	-
Thinned lyes	+	+	+	+
Concentrated lyes	+	-	+	-
Acetic acid 10%	+	-	-	-
Mineral oil	-	-	-	-
Light petrol	-	-	-	-
Ethyl alcohol	+	+	+	-
Acetone	-	-	-	-
Butyl acetate	-	-	-	-
Toluol	-	-	-	-
Carbon tetrachloride	-	-	-	-

A “+” means that in the chemical resistance test the test pieces showed no change in appearance and no weight change exceeding ± 3%.

Life test = 177 hours immersed.

MANUFACTURE OF MAGNETS

Magnets can be produced by rolling, calendaring, transfer-moulding or extrusion, after which the magnets may be further processed by cutting tools, die-cutting machines, shears and high-speed diamond cutting wheels.

DIRECTION OF MAGNETIZATION

Ferroxdure P30 is an isotropic material and may therefore be magnetized in any direction. Where magnets are to be supplied magnetized, the pole pattern must be shown on the magnet drawing.

QUALITY AND FINISH

The material allows magnets to be produced having a good, clean finish, and appearance according to the appropriate visual limit samples.

TYPICAL DEMAGNETIZATION CURVE (25 °C)

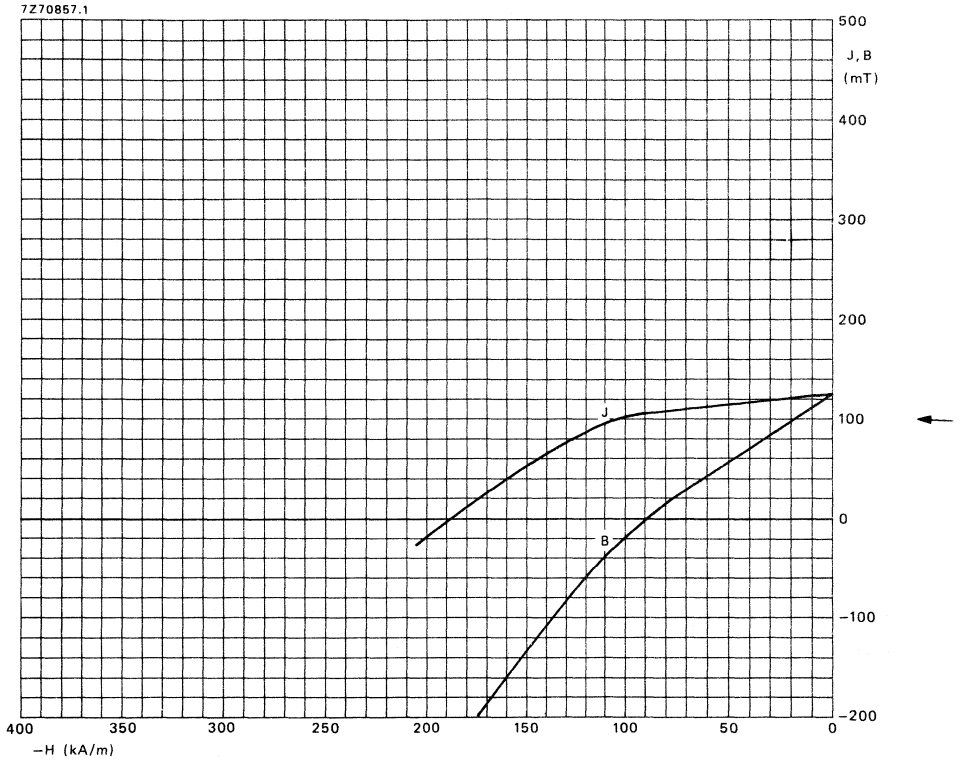

FERROXDURE P40B

isotropic plastic-bonded ceramic material

GENERAL

This specification relates to tests carried out on test pieces made from each batch of material taken from normal production. The test piece is an extruded strip with a cross-section of approximately 11 mm x 3 mm.

Magnets manufactured from this material conform generally to this specification but, owing to the method of manufacture and to the variation in size and shape, some limits cannot always be realized, or indeed checked by measurement on the magnet. However, a minimum-flux test or similar test described in each magnet specification, can be used as a basis for performance guarantees.

→ COMPOSITION

Ferroxdure P40B is a barium ferrite, the main constituent being $\text{BaFe}_{12}\text{O}_{19}$ with 10% (by weight) of thermoplastic material added.

MAGNETIC AND ELECTRICAL PROPERTIES OF THE TEST PIECE

Temperature of the test piece is 25 ± 2 °C unless otherwise specified.

		typ.	min.	typ.	min.
Remanence	B_r	145	135 mT	1450	1350 Gs
Coercivity	H_{cB}	96	88 kA/m	1210	1110 Oe
Polarization coercivity	H_{cJ}	190	kA/m	2390	Oe
Maximum BH product	$(BH)_{\max}$	3,6	3,2 kJ/m ³	0,45	0,4 MGsOe
Temperature coefficient of B_r (-20 to +90 °C)		-0,2	%/K	-0,2	%/°C
Saturation field strength	H_{sat}	800	kA/m	10 000	Oe
Resistivity	ρ		$10^6 \Omega\text{m}$		$10^8 \Omega\text{cm}$

After storage of the magnetized test piece for 48 h at -30 °C and 48 h at +90 °C the changes in its magnetic properties do not exceed $\pm 3\%$ of the initial values.

PHYSICAL PROPERTIES

Density typ. $3,7 \times 10^3 \text{ kg/m}^3$ ($3,7 \text{ g/cm}^3$)

Maximum temperature range (continuous) -50 to +90 °C

→ Flame retardance of P40B to UL94-HB

PHYSICAL PROPERTIES (continued)

Typical values at ambient temperature after
100 h storage at:

		-50 ± 2 °C	25 ± 2 °C	70 ± 2 °C
Shore C hardness after 10 s	P40	80 ± 10	80 ± 10	90 ± 10
	P40F	90 ± 10	90 ± 10	90 ± 10
Tensile strength at uniform speed of 50 mm/min	P40	400	350	500 N/cm ²
	P40F	800	800	950 N/cm ²
Diameter of mandrel around which the test piece can be bent without cracking or breaking; broad face in contact with mandrel	P40	15	15	25 mm
	P40F	20	20	25 mm
Linear shrinkage		0,25	0,25	2 %

CHEMICAL RESISTANCE

	25 °C		70 °C	
	up to 5 h	life test	up to 5 h	life test
Water	+	+	+	+
Thinned acids	+	-	+	-
Concentrated acids	-	-	-	-
Thinned lyes	+	+	+	-
Concentrated lyes	+	-	+	-
Acetic acid 10%	+	-	-	-
Mineral oil	+	-	-	-
Light petrol	-	-	-	-
Ethyl alcohol	+	+	+	+
Acetone	+	-	-	-
Butyl acetate	-	-	-	-
Toluol	-	-	-	-
Carbon tetrachloride	-	-	-	-

A “+” means that in the chemical resistance test the test pieces showed no change in appearance and no weight change exceeding ± 3%.

MANUFACTURE OF MAGNETS

Magnets can be produced by rolling, calendaring, transfer-moulding or extrusion, after which the magnets may be further processed by cutting tools, die-cutting machines, shears and high-speed diamond cutting wheels.

DIRECTION OF MAGNETIZATION

Ferroxdure P40B is an isotropic material and may therefore be magnetized in any direction. ←
Where magnets are to be supplied magnetized, the pole pattern must be shown on the magnet drawing.

QUALITY AND FINISH

The material allows magnets to be produced having a good, clean finish, and appearance according to the appropriate visual limit samples.

FERROXDURE P40B
MATERIAL
SPECIFICATION

TYPICAL DEMAGNETIZATION CURVE (25 °C)

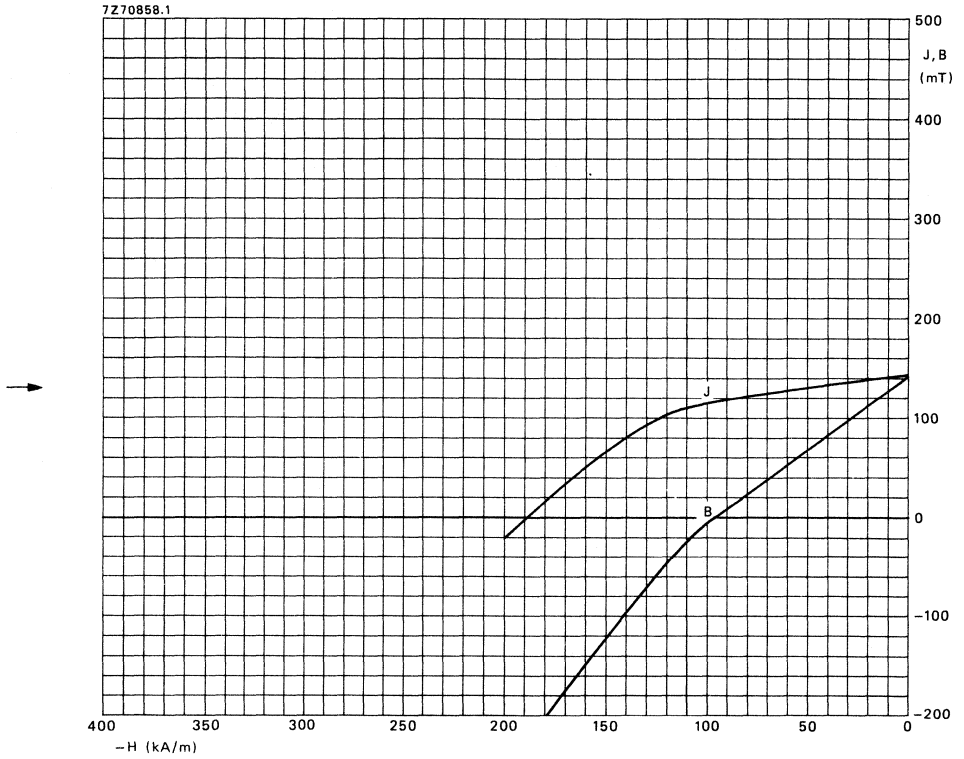

FERROXDURE SP10

isotropic plastic-bonded ceramic material

GENERAL

This specification relates to tests carried out on test pieces made from each batch of material taken from normal production. The test piece has dimensions of approximately 6 mm x 12 mm x 20 mm for magnetic and electrical tests and 6 mm x 4 mm x 55 mm for mechanical and thermal tests.

Magnets manufactured from this material conform generally to this specification but, owing to the method of manufacture and to the variation in size and shape, some limits cannot always be realized, or indeed checked by measurement on the magnet. However, a minimum-flux test or similar test described in each magnet specification, can be used as a basis for performance guarantees.

COMPOSITION

Ferroxdure SP10 is a barium ferrite, the main constituent being $\text{BaFe}_{12}\text{O}_{19}$ with 25% (by weight) of thermoplastic material added.

MAGNETIC AND ELECTRICAL PROPERTIES OF THE TEST PIECE

Temperature of the test piece is 25 ± 2 °C unless otherwise specified.

		typ.	min.	typ.	min.
Remanence	B_r	80	75 mT	800	750 Gs
Coercivity	H_{cB}	58	54 kA/m	729	679 Oe
Polarization coercivity	H_{cJ}	190	kA/m	2390	Oe
Maximum BH product	$(BH)_{\max}$	0,9	0,8 kJ/m ³	0,11	0,1 MGsOe
Temperature coefficient of B_r (-20 to +100 °C)		-0,2	%/K	-0,2	%/°C
Saturation field strength	H_{sat}	800	kA/m	10 000	Oe
Resistivity	ρ		$10^8 \Omega\text{m}$		$10^{10} \Omega\text{cm}$

After storage of the magnetized test piece for 48 h at -30 °C and 48 h at +80 °C the changes in its magnetic properties do not exceed $\pm 3\%$ of the initial values.

PHYSICAL PROPERTIES

Density	typ.	$2,5 \times 10^3 \text{ kg/m}^3$ (2,5 g/m ³)
Coefficient of linear expansion (20 to 90 °C)	typ.	$5 \cdot 10^{-6} / \text{K}$
Maximum permissible temperature		
continuous		100 °C
short periods		120 °C

PHYSICAL PROPERTIES (continued)

Test piece 6 mm x 4 mm x 55 mm produced by injection moulding

Linear shrinkage after 100 h at 90 °C	<	0,25 %
Moisture absorption during storage in water	<	0,25 % (by weight)
Flame retardance of SP10		to UL94-HB

Flexural strength test

Rate of crosshead motion		50 mm/min
Length of span		40 mm
Flexural strength after 100 h		
at 25 ± 3 °C	typ.	200 N/cm ²
at 100 ± 3 °C	typ.	200 N/cm ²

Impact strength test (pendulum type)

Striker: 50 Ncm, length of span 40 mm

Impact strength after 100 h		
at 25 ± 3 °C	typ.	0,4 J/cm ²
at 100 ± 3 °C	typ.	0,4 J/cm ²

CHEMICAL RESISTANCE

	25 °C		70 °C	
	up to 5 h	life test	up to 5 h	life test
Water	+	+	+	+
Thinned acids	+	—	—	—
Concentrated acids (except HCl)	—	—	—	—
Concentrated HCl	—	—	—	—
Thinned lyes	+	+	+	—
Concentrated lyes	+	+	+	—
Acetic acid 10%	+	+	+	+
Mineral oil	+	+	+	—
Petrol	+	—	—	—
Ethyl alcohol	+	+	+	—
Ethyl glycol
Acetone	+	—	—	—
Butyl acetate	+	—	—	—
Toluol	+	—	—	—
Carbon tetrachloride	—	—	—	—

A "+" means that in the chemical resistance test the test pieces showed no change in appearance and no weight change exceeding ± 1%. A "." means not tested.

MANUFACTURE OF MAGNETS

Magnets are produced by injection moulding. Turning and milling with special (steel) tools is possible.

DIRECTION OF MAGNETIZATION

Ferroxdure SP10 is an isotropic material and may therefore be magnetized in any direction. Where magnets are to be supplied magnetized, the pole pattern must be shown on the magnet drawing.

QUALITY AND FINISH

The material allows magnets to be produced having a good, clean finish, and appearance according to the appropriate visual limit samples.

TYPICAL DEMAGNETIZATION CURVE (25 °C)

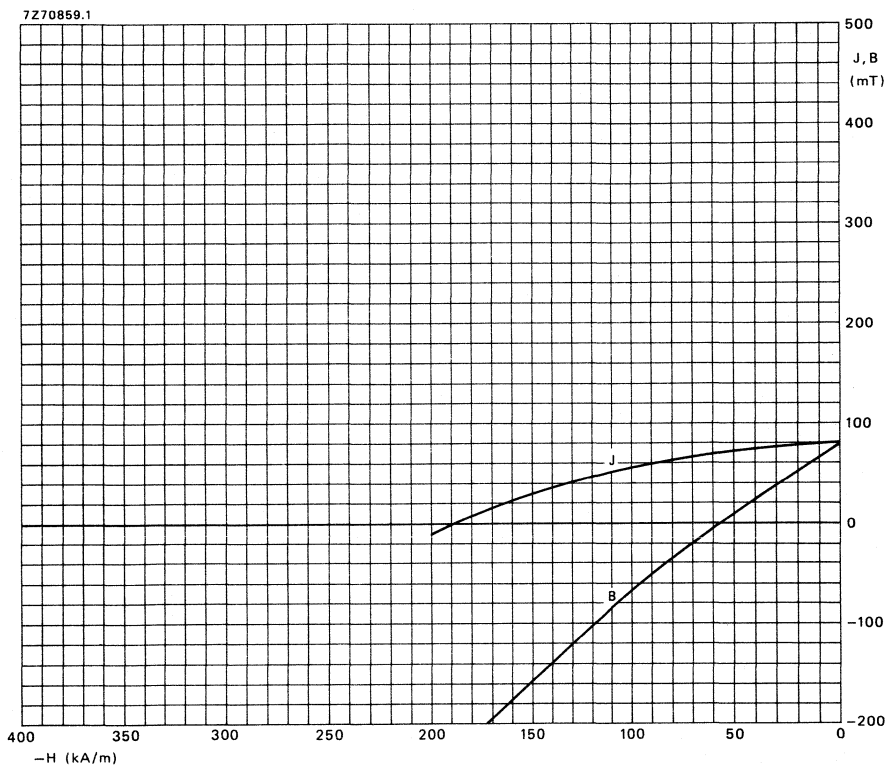

FERROXDURE SP50

isotropic plastic-bonded ceramic material

GENERAL

This specification relates to tests carried out on test pieces made from each batch of material taken from normal production. The test piece has dimensions of approximately 6 mm x 12 mm x 20 mm for magnetic and electrical tests and 6 mm x 4 mm x 55 mm for mechanical and thermal tests.

Magnets manufactured from this material conform generally to this specification but, owing to the method of manufacture and to the variation in size and shape, some limits cannot always be realized, or indeed checked by measurement on the magnet. However, a minimum-flux test or similar test described in each magnet specification, can be used as a basis for performance guarantees.

COMPOSITION

Ferroxdure SP50 is a barium ferrite, the main constituent being $\text{BaFe}_{12}\text{O}_{19}$ with 7% (by weight) of thermoplastic material added.

MAGNETIC AND ELECTRICAL PROPERTIES OF THE TEST PIECE

Temperature of the test piece is 25 ± 2 °C unless otherwise specified.

		typ.	min.	typ.	min.
Remanence	B_r	155	150 mT	1550	1500 Gs
Coercivity	H_{cB}	104	100 kA/m	1310	1260 Oe
Polarization coercivity	H_{cJ}	190	kA/m	2390	Oe
Maximum BH product	$(BH)_{\max}$	4,4	4 kJ/m ³	0,55	0,5 MGsOe
Temperature coefficient of B_r (-20 to +100 °C)		-0,2	%/K	-0,2	%/°C
Saturation field strength	H_{sat}	800	kA/m	10 000	Oe
Resistivity	ρ		$10^4 \Omega\text{m}$		$10^6 \Omega\text{cm}$

After storage of the magnetized test piece for 48 h at -30 °C and 48 h at +80 °C the changes in its magnetic properties do not exceed $\pm 3\%$ of the initial values.

PHYSICAL PROPERTIES

Density	typ.	$3,9 \times 10^3 \text{ kg/m}^3$ (3,9 g/cm ³)
Coefficient of linear expansion (20 to 90 °C)	typ.	$24 \cdot 10^{-6} / \text{K}$
Maximum permissible temperature		
continuous		100 °C
short periods		120 °C

PHYSICAL PROPERTIES (continued)

Test piece 6 mm x 4 mm x 55 mm produced by injection moulding

Linear shrinkage after 100 h at 80 °C	<	0,3 %
Moisture absorption during storage in water	<	1 % (by weight)

Flexural strength test

Rate of crosshead motion		50 mm/min
Length of span		40 mm

Flexural strength after 100 h		
at 25 ± 3 °C	typ.	100 N/cm ²
at 100 ± 3 °C	typ.	100 N/cm ²

Impact strength test (pendulum type)

Striker: 50 Ncm, length of span 40 mm

Impact strength after 100 h		
at 25 ± 3 °C	typ.	0,1 J/cm ²
at 100 ± 3 °C	typ.	0,1 J/cm ²

CHEMICAL RESISTANCE

	25 °C		70 °C	
	up to 5 h	life test	up to 5 h	life test
Water	+	+	+	+
Thinned acids	+	—	—	—
Concentrated acids	—	—	—	—
Thinned lyes	+	+	+	+
Concentrated lyes	+	+	+	—
Acetic acid 10%	+	—	+	—
Mineral oil	+	+	—	—
Light petrol	+	—	—	—
Ethyl alcohol	+	+	+	—
Acetone	—	—	—	—
Butyl acetate	—	—	—	—
Toluol	—	—	—	—
Carbon tetrachloride	—	—	—	—

A “+” means that in the chemical resistance test the test pieces showed no change in appearance and no weight change exceeding ± 1%.

Life test = 150 h immersed.

MANUFACTURE OF MAGNETS

Magnets are produced by injection moulding. Turning and milling with special (steel) tools is possible.

DIRECTION OF MAGNETIZATION

Ferroxdure SP50 is an isotropic material and may therefore be magnetized in any direction. Where magnets are to be supplied magnetized, the pole pattern must be shown on the magnet drawing.

QUALITY AND FINISH

The material allows magnets to be produced having a good, clean finish, and appearance according to the appropriate visual limit samples.

TYPICAL DEMAGNETIZATION CURVE (25 °C)

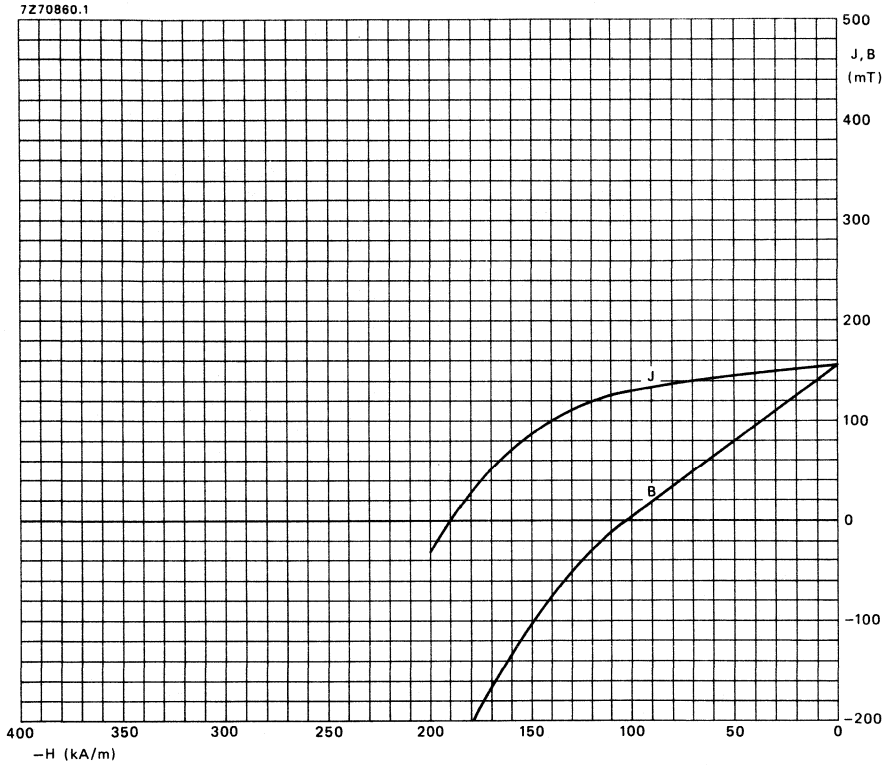

FERROXDURE SP130

anisotropic plastic-bonded ceramic material

GENERAL

This specification relates to tests carried out on test pieces made from each batch of material taken from normal production. The test piece has dimensions of approximately 6 mm x 12 mm x 20 mm for magnetic and electrical tests and 6 mm x 4 mm x 55 mm for mechanical and thermal tests. The preferred direction of magnetization parallel to the 6 mm dimension.

Magnets manufactured from this material conform generally to this specification but, owing to the method of manufacture and to the variation in size and shape, some limits cannot always be realized, or indeed checked by measurement on the magnet. However, a minimum-flux test or similar test described in each magnet specification, can be test used as a basis for performance guarantees.

COMPOSITION

Ferroxdure SP130 is a barium ferrite, the main constituent being $\text{BaFe}_{12}\text{O}_{19}$ with 10% (by weight) of thermoplastic material added.

MAGNETIC AND ELECTRICAL PROPERTIES OF THE TEST PIECE (preferred direction)

Temperature of the test piece is 25 ± 2 °C unless otherwise specified.

		typ.	min.	typ.	min.
Remanence	B_r	240	230 mT	2400	2300 Gs
Coercivity	H_{cB}	175	167 kA/m	2200	2100 Oe
Polarization coercivity	H_{cJ}	240	kA/m	3020	Oe
Maximum BH product	$(BH)_{\max}$	11	10 kJ/m ³	1,4	1,3 MGsOe
Temperature coefficient of B_r (-20 to + 100 °C)		-0,2	%/K	-0,2	%/°C
Saturation field strength	H_{sat}	800	kA/m	10 000	Oe
Resistivity	ρ		$10^5 \Omega\text{m}$		$10^7 \Omega\text{cm}$

After storage of the magnetized test piece for 48 h at -30 °C and 48 h at +90 °C the changes in its magnetic properties do not exceed $\pm 5\%$ of the initial values.

PHYSICAL PROPERTIES

Density	typ.	$3,5 \times 10^3 \text{ kg/m}^3$ (3,5 g/cm ³)
Coefficient of linear expansion (20 to 90 °C)	typ.	$5 \cdot 10^{-6} / \text{K}$
Maximum permissible temperature		
continuous		100 °C
short periods		120 °C

PHYSICAL PROPERTIES (continued)

Test piece 6 mm x 4 mm x 55 mm produced by injection moulding

Linear shrinkage after 24 h at 125 °C	<	0,1 %
Moisture absorption during storage in water	<	0,05 % (by weight)

Flexural strength test

Rate of crosshead motion		50 mm/min
Length of span		40 mm
Flexural strength after 100 h		
at 25 ± 3 °C	typ.	60 N/cm ²
at 100 ± 3 °C	typ.	60 N/cm ²

Impact strength test (pendulum type)

Striker: 50 Ncm, length of span 40 mm

Impact strength after 100 h		
at 25 ± 3 °C	typ.	0,1 J/cm ²
at 100 ± 3 °C	typ.	0,1 J/cm ²

CHEMICAL RESISTANCE

	25 °C		70 °C	
	up to 5 h	life test	up to 5 h	life test
Water	+	+	+	+
Thinned acids	+	—	—	—
Concentrated acids	—	—	—	—
Thinned lyes	+	+	+	—
Concentrated lyes	+	+	+	—
Acetic acid 10%	+	+	+	+
Mineral oil	+	+	+	—
Light petrol	+	—	—	—
Ethyl alcohol	+	+	+	—
Acetone	+	—	—	—
Butyl acetate	+	—	—	—
Toluol	+	—	—	—
Carbon tetrachloride	+	—	—	—

A “+” means that in the chemical resistance test the test pieces showed no change in appearance and no weight change exceeding ± 1%.

Life test = 170 h immersed.

MANUFACTURE OF MAGNETS

Magnets are produced by injection moulding, afterwards the products may be machined by turning and milling with special (steel) tools, by grinding using diamond tools and also by vibro-finishing.

DIRECTION OF MAGNETIZATION

Ferroxdure SP130 is an anisotropic material, and has therefore a preferred direction of magnetization (Magnetic Axis), which must be shown on the magnet drawing.

**FERROXDURE SP130
MATERIAL
SPECIFICATION**

QUALITY AND FINISH

The material allows magnets to be produced having a good, clean finish and appearance according to the appropriate visual limit samples.

TYPICAL DEMAGNETIZATION CURVE (25 °C)

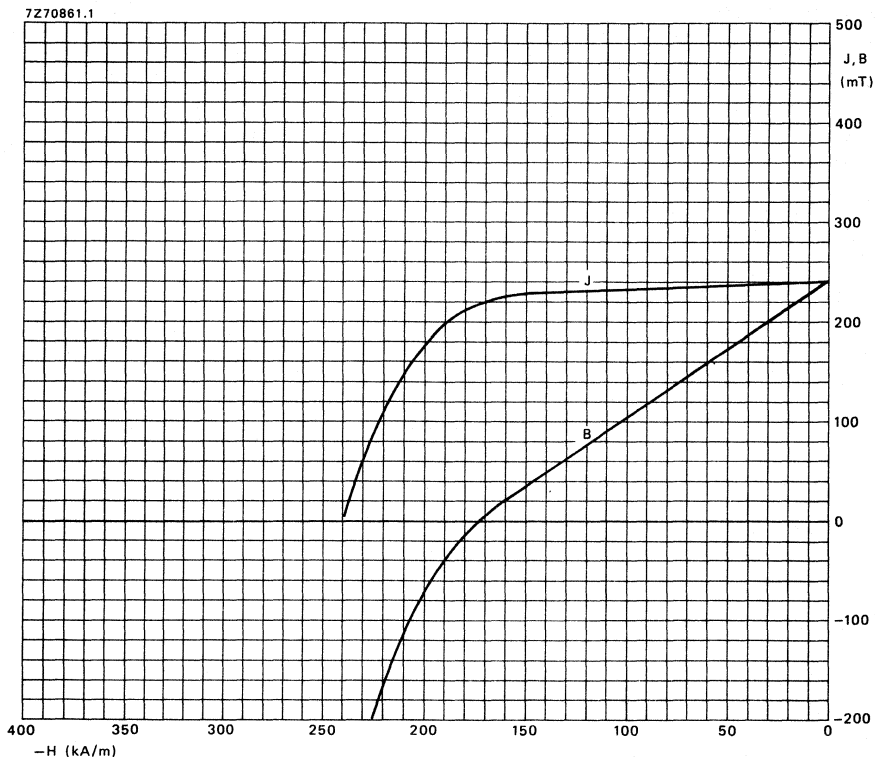

FERROXDURE SP170

anisotropic plastic-bonded ceramic material

GENERAL

This specification relates to tests performed on test pieces which are processed together with each batch in normal production. The test piece has dimensions of approximately 6 mm x 12 mm x 20 mm for magnetic and electrical tests and 6 mm x 4 mm x 55 mm for mechanical and thermal tests. Preferred direction of magnetization parallel to the 6 mm dimension.

Magnets manufactured from this material conform generally to this specification but, owing to the method of manufacture and to the variation in size and shape, some limits cannot always be realized, or indeed checked by measurement on the magnet. However, a minimum-flux test or similar test described in each magnet specification, can be used as a basis for performance guarantees.

COMPOSITION

Ferroxdure SP170 is a mixture of barium and strontium ferrite, with 6% (by weight) of thermoplastic material added.

MAGNETIC AND ELECTRICAL PROPERTIES OF THE TEST PIECE (preferred direction)

Temperature of test piece is 25 ± 2 °C unless otherwise specified.

		typ.	min.		typ.	min.
Remanence	B_r	270	260	mT	2700	2600 Gs
Coercivity	H_{cB}	196	188	kA/m	2460	2360 Oe
Polarization coercivity	H_{cJ}	260		kA/m	3270	Oe
Maximum BH product	$(BH)_{max}$	14	13	kJ/m ³	1,75	1,6 MGsOe
Temperature coefficient of B_r (-20 to + 100 °C)		-0,2		%/K	-0,2	%/°C
Temperature coefficient of H_{cJ} (-20 to + 100 °C)				%/K		%/°C
Saturation field strength	H_{sat}	800		kA/m	10 000	Oe
Resistivity	ρ		10^5	Ωm		10^7 Ωcm

After storage of the magnetized test piece for 48 h at -30 °C and 48 h at + 90 °C the changes in its magnetic properties do not exceed $\pm 5\%$ of the initial values.

PHYSICAL PROPERTIES

Density	typ.	$3,9 \times 10^3$ kg/m ³	(3,9 g/cm ³)
Coefficient of linear expansion (20 to 90 °C)	typ.	$5 \cdot 10^{-6}/K$	
Maximum permissible temperature			
continuous		100 °C	
short periods		120 °C	

**FERROXDURE SP170
MATERIAL
SPECIFICATION**

PHYSICAL PROPERTIES (continued)

Test piece 6 mm x 4 mm x 55 mm produced by injection moulding

Linear shrinkage after 24 h at 125 °C	<	0,1 %
Moisture absorption during storage in water	<	0,05 % (by weight)

Flexural strength test

Rate of crosshead motion 20 mm/min
Length of span 40 mm

Flexural strength after 100 h

at 25 ± 3 °C	typ.	30 C/cm ²
at 100 ± 3 °C	typ.	40 N/cm ²

Impact strength test (pendulum type)

Striker: 50 Ncm, length of span 40 mm

Impact strength after 100 h

at 25 ± 3 °C	typ.	0,08 J/cm ²
at 100 ± 3 °C	typ.	0,08 J/cm ²

CHEMICAL RESISTANCE

	25 °C		70 °C	
	up to 5 H	life test	up to 5 h	life test
Water	+	+	+	+
Thinned acids	+	—	—	—
Concentrated acids	—	—	—	—
Thinned lyes	+	+	+	—
Concentrated lyes	+	+	+	—
Acetic acid 10%	+	+	+	+
Mineral oil	+	+	+	—
Light petrol	+	—	—	—
Ethyl alcohol	+	+	+	—
Acetone	+	—	—	—
Butyl acetate	+	—	—	—
Toluol	+	—	—	—
Carbon tetrachloride	+	—	—	—

A "++" means that in the chemical resistance test the test pieces showed no change in appearance and no mass change exceeding ± 1%.

Life test = 170 h immersed.

MANUFACTURE OF MAGNETS

Magnets are produced by injection moulding. After complete demagnetization the products may be machined by turning and milling with special (steel) tools or by grinding using diamond tools.

DIRECTION OF MAGNETIZATION

Ferroxdure SP170 is an anisotropic material, and has therefore a preferred direction of magnetization (Magnetic Axis), which must be shown on the magnet drawing.

QUALITY AND FINISH

The material allows magnets to be produced having a good, clean finish and appearance according to the appropriate visual limit samples.

APPLICATION

Where high-coercivity permanent magnets are required.

TYPICAL DEMAGNETIZATION CURVE (25 °C)

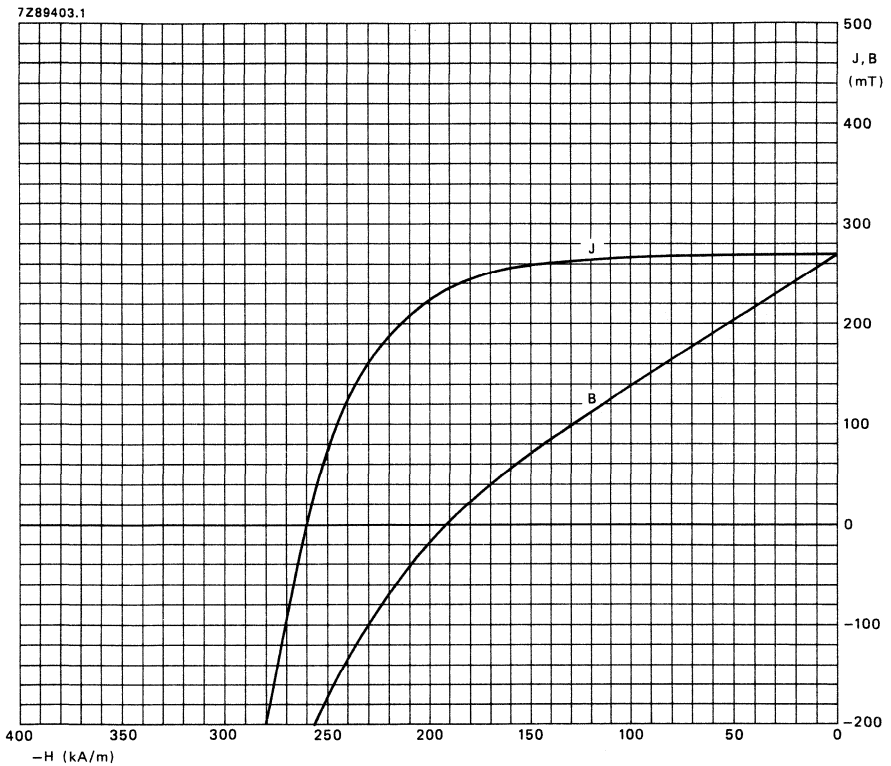

FERROXDURE 270
anisotropic ceramic material

GENERAL

This specification relates to tests carried out on test pieces made from each batch of material taken from normal production. The test piece has dimensions of approximately ϕ 35 mm x 15 mm.

Magnets manufactured from this material conform generally to this specification but, owing to the method of manufacture and to the variation in size and shape, some limits cannot always be realized, or indeed checked by measurement on the magnet. However, a minimum-flux test or similar test described in each magnet specification, can be test used as a basis for performance guarantees.

COMPOSITION

Ferroxdure 270 is a strontium ferrite, the main constituent being $\text{SrFe}_{12}\text{O}_{19}$.

→ **MAGNETIC AND ELECTRICAL PROPERTIES OF THE TEST PIECE**

Temperature of the test piece is 25 ± 2 °C unless otherwise specified.

		typ.	min.	typ.	min.
Remanence	B_r	350	340 mT	3500	3400 Gs
Coercivity	H_{cB}	260	250 kA/m	3300	3100 Oe
Polarization coercivity	H_{cJ}	335	320 kA/m	4200	4000 Oe
Maximum BH product	$(BH)_{\max}$	22,8	21,5 kJ/m ³	2,9	2,7 MGsOe
Magnetic flux density corresponding to $(BH)_{\max}$	B_d	170	mT	1700	Gs
Magnetic field strength corresponding to $(BH)_{\max}$	H_d	135	kA/m	1700	Oe
Recoil permeability	μ_{rec}	1,1		1,1	
Temperature coefficient of B_r (-40 to + 200 °C)		-0,2	%/K	-0,2	%/°C
Temperature coefficient of H_{cJ} (-40 to + 200 °C)		≈0,95	kA/m/K	≈ 12	Oe/°C
Saturation field strength	H_{sat}		1100 kA/m		14 000 Oe
Resistivity	ρ	10^4	Ωm	10^6	Ωcm
Curie point		450	°C	450	°C

PHYSICAL PROPERTIES

Density	typ.	$4,6 \times 10^3$ kg/m ³	(4,6 g/cm ³)
Coefficient of linear expansion (20 to 300 °C)		⊥ MA 8 and // MA 13	$\cdot 10^{-6}$ /K
Hardness (Moh's scale)	typ.	6,5	

DIRECTION OF MAGNETIZATION

Ferroxdure 270 is an anisotropic material, and has therefore a preferred direction of magnetization (Magnetic Axis), which must be shown on the magnet drawing.

QUALITY AND FINISH

The material allows magnets to be produced having a good, clean finish and appearance according to the appropriate visual limit samples.

TYPICAL DEMAGNETIZATION CURVE (25 °C)

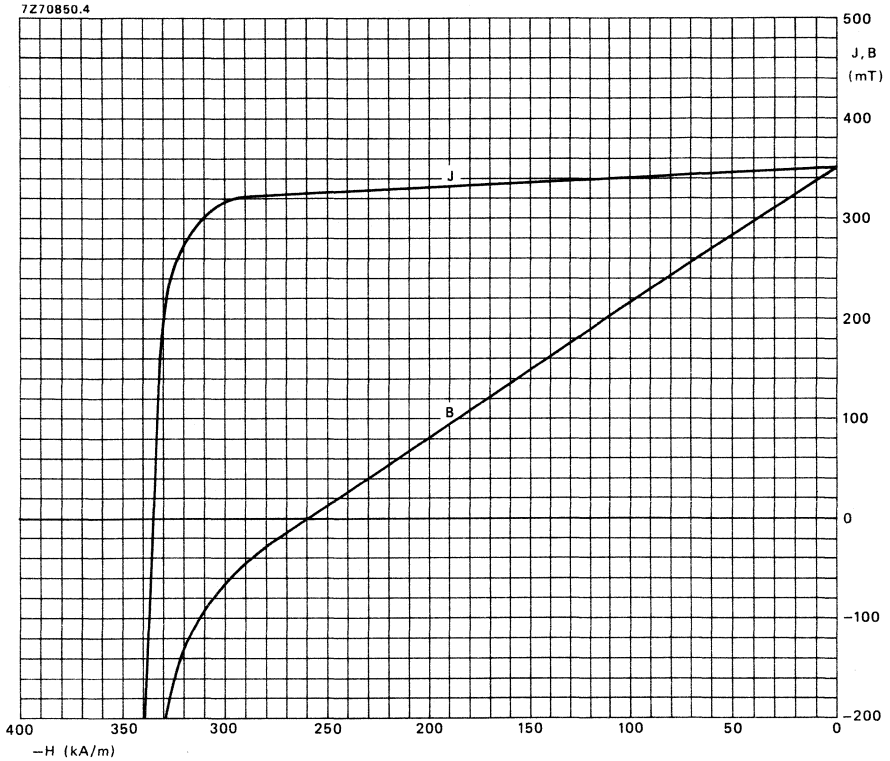

FERROXDURE 300
anisotropic ceramic material

GENERAL

This specification relates to tests carried out on test pieces made from each batch of material taken from normal production. The test piece has dimensions of approximately ϕ 35 mm x 12 mm.

Magnets manufactured from this material conform generally to this specification but, owing to the method of manufacture and to the variation in size and shape, some limits cannot always be realized, or indeed checked by measurement on the magnet. However, a minimum-flux test or similar test described in each magnet specification can be used as a basis for performance guarantees.

COMPOSITION

Ferroxdure 300 is a barium ferrite, the main constituent being BaFe₁₂O₁₉.

MAGNETIC AND ELECTRICAL PROPERTIES OF THE TEST PIECE

Temperature of the test piece is 25 ± 2 °C unless otherwise specified.

		typ.	min.	typ.	min.
Remanence	B _r	400	390 mT	4000	3900 Gs
Coercivity	H _{cB}	160	145 kA/m	2000	1800 Oe
Polarization coercivity	H _{cJ}	165	150 kA/m	2050	1850 Oe
Maximum BH product	(BH) _{max}	29,5	28,0 kJ/m ³	3,7	3,5 MGsOe
Magnetic flux density corresponding to (BH) _{max}	B _d	220	mT	2200	Gs
Magnetic field strength corresponding to (BH) _{max}	H _d	135	kA/m	1700	Oe
Recoil permeability	μ _{rec}	1,1		1,1	
Temperature coefficient of B _r (-40 to +200 °C)		-0,2	%/K	-0,2	%/°C
Temperature coefficient of H _{cJ} (-40 to +200 °C)		~ 0,8	kA/m/K	~ 10	Oe/°C
Saturation field strength	H _{sat}		560 kA/m	7000	Oe
Resistivity	ρ	10 ⁴	Ωm	10 ⁶	Ωcm
Curie point		450	°C	450	°C

PHYSICAL PROPERTIES

Density	typ.	4,9 x 10 ³ kg/m ³	(4,9 g/cm ³)
Coefficient of linear expansion (20 to 300 °C)		⊥ MA 8 and // MA 13	· 10 ⁻⁶ /K
Hardness (Moh's scale)	typ.	6,5	

DIRECTION OF MAGNETIZATION

Ferroxdure 300 is an anisotropic material, and has therefore a preferred direction of magnetization (Magnetic Axis), which must be shown on the magnet drawing.

QUALITY AND FINISH

The material allows magnets to be produced having a good, clean finish and appearance according to the appropriate visual limit samples.

TYPICAL DEMAGNETIZATION CURVE (25 °C)

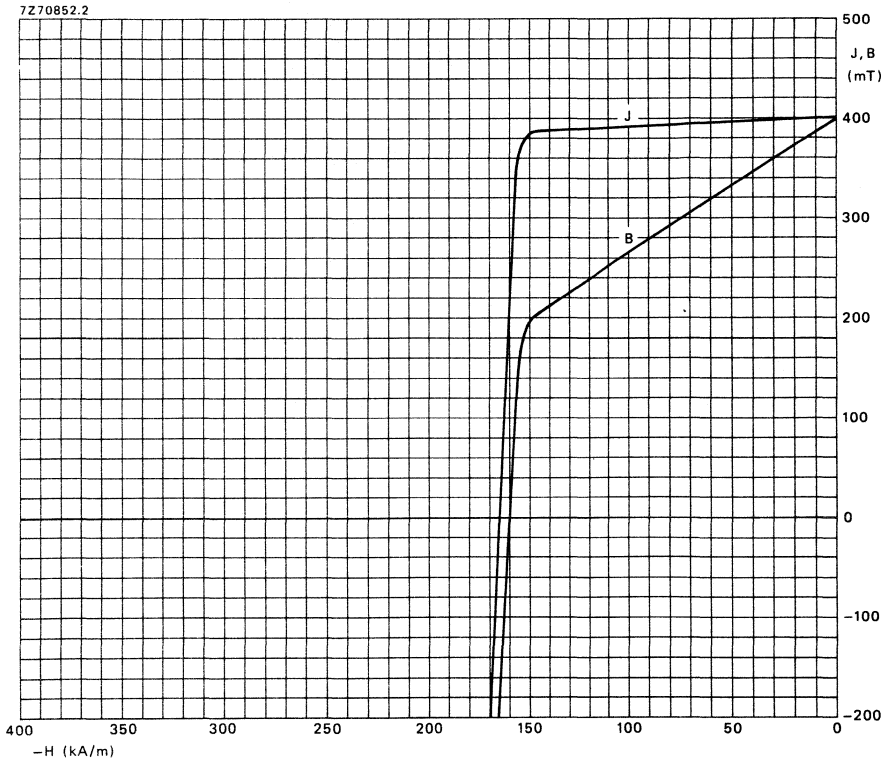

FERROXDURE 330
anisotropic ceramic material

GENERAL

This specification relates to tests carried out on test pieces made from each batch of material taken from normal production. The test piece has dimensions of approximately $\phi 35 \times 12$ mm.

Magnets manufactured from this material conform generally to this specification but, owing to the method of manufacture and to the variation in size and shape, some limits cannot always be realized, or indeed checked by measurement on the magnet. However, a minimum-flux test or similar test described in each magnet specification, can be used as a basis for performance guarantees.

COMPOSITION

Ferroxdure 330 is a strontium ferrite, the main constituent being $\text{SrFe}_{12}\text{O}_{19}$.

MAGNETIC AND ELECTRICAL PROPERTIES OF THE TEST PIECE

Temperature of the test piece is 25 ± 2 °C unless otherwise specified.

		typ.	min.	typ.	min.
Remanence	B_r	370	360 mT	3700	3600 Gs
Coercivity	H_{cB}	245	230 kA/m	3100	2900 Oe
Polarization coercivity	H_{cJ}	255	240 kA/m	3200	3000 Oe
Maximum BH product	$(BH)_{\max}$	25,5	24,1 kJ/m ³	3,2	3,0 MGsOe
Magnetic flux density corresponding to $(BH)_{\max}$	B_d	180	mT	1800	Gs
Magnetic field strength corresponding to $(BH)_{\max}$	H_d	140	kA/m	1750	Oe
Recoil permeability	μ_{rec}	1,1		1,1	
Temperature coefficient of B_r (−40 to +200 °C)		−0,2	%/K	−0,2	%/°C
Temperature coefficient of H_{cJ} (−40 to +200 °C)		$\approx 0,95$	kA/m/°C	≈ 12	Oe/°C
Saturation field strength	H_{sat}		875 kA/m		11 000 Oe
Resistivity	ρ	10^4	Ωm	10^6	Ωcm
Curie point		450	°C	450	°C

PHYSICAL PROPERTIES

Density	typ.	$4,65 \times 10^3$ kg/m ³	(4,65 g/cm ³)
Coefficient of linear expansion (20 to 300 °C)	\perp MA 8 and \parallel MA 13		$\cdot 10^{-6}/\text{K}$
Hardness (Moh's scale)	typ.		6,5

DIRECTION OF MAGNETIZATION

Ferroxdure 330 is an anisotropic material, and has therefore a preferred direction of magnetization (Magnetic Axis), which must be shown on the magnet drawing.

QUALITY AND FINISH

The material allows magnets to be produced having a good, clean finish and appearance according to the appropriate visual limit samples.

TYPICAL DEMAGNETIZATION CURVE (25 °C)

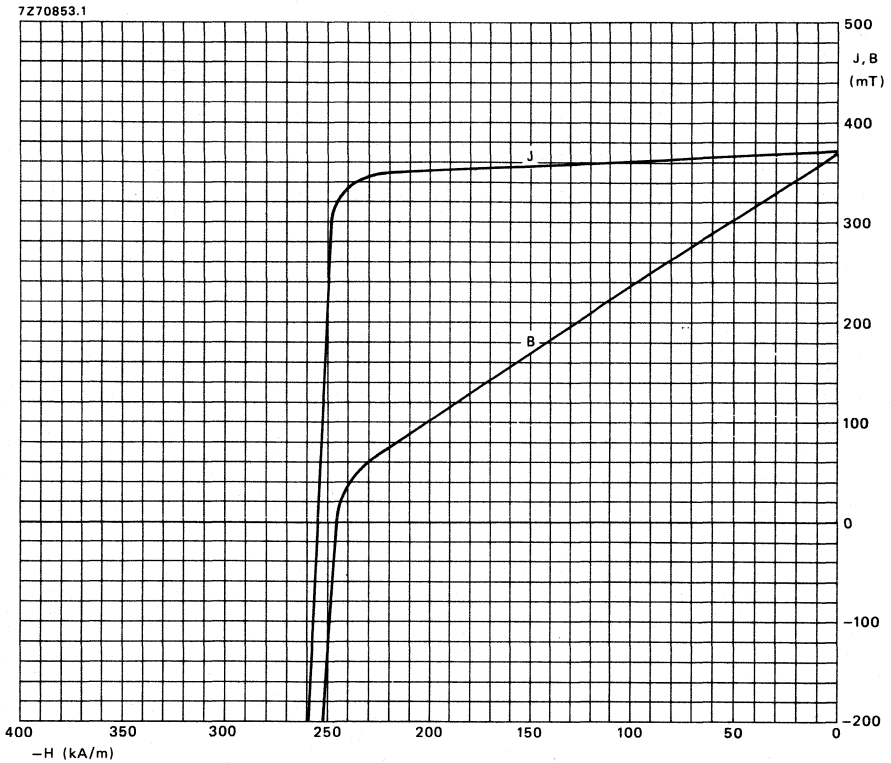

FERROXDURE 380
anisotropic ceramic material

GENERAL

This specification relates to tests carried out on test pieces made from each batch of material taken from normal production. The test piece has dimensions of approximately $\phi 35$ mm x 12 mm.

Magnets manufactured from this material conform generally to this specification but, owing to the method of manufacture and to the variation in size and shape, some limits cannot always be realized, or indeed checked by measurement on the magnet. However, a minimum-flux test or similar test described in each magnet specification, can be used as a basis for performance guarantees.

COMPOSITION

Ferroxdure 380 is a strontium ferrite, the main constituent being $\text{SrFe}_{12}\text{O}_{19}$.

MAGNETIC AND ELECTRICAL PROPERTIES OF THE TEST PIECE

Temperature of the test piece is 25 ± 2 °C unless otherwise specified.

		typ.	min.	typ.	min.
Remanence	B_r	390	380 mT	3900	3800 Gs
Coercivity	H_{cB}	265	250 kA/m	3300	3100 Oe
Polarization coercivity	H_{cJ}	275	260 kA/m	3500	3300 Oe
→ Maximum BH product	$(BH)_{\max}$	28,2	26,9 kJ/m ³	3,6	3,4 MGsOe
Magnetic flux density corresponding to $(BH)_{\max}$	B_d	190	mT	1900	Gs
→ Magnetic field strength corresponding to $(BH)_{\max}$	H_d	150	kA/m	1850	Oe
Recoil permeability	μ_{rec}	1,1		1,1	
Temperature coefficient of B_r (-40 to +200 °C)		-0,2	%/K	-0,2	%/°C
Temperature coefficient of H_{cJ} (-40 to +200 °C)		~0,95	kA/m/K	~12	Oe/°C
Saturation field strength	H_{sat}		955 kA/m		12 000 Oe
Resistivity	ρ	10^4	Ωm	10^6	Ωcm
Curie point		450	°C	450	°C

PHYSICAL PROPERTIES

Density	typ.	$4,75 \times 10^3$ kg/m ³	(4,75 g/cm ³)
Coefficient of linear expansion (20 to 300 °C)	⊥ MA 8 and // MA 13		$\cdot 10^{-6}/\text{K}$
Hardness (Moh's scale)	typ.	6,5	

DIRECTION OF MAGNETIZATION

Ferroxdure 380 is an anisotropic material, and has therefore a preferred direction of magnetization (Magnetic Axis), which must be shown on the magnet drawing.

QUALITY AND FINISH

The material allows magnets to be produced having a good, clean finish and appearance according to the appropriate visual limit samples.

TYPICAL DEMAGNETIZATION CURVE (25 °C)

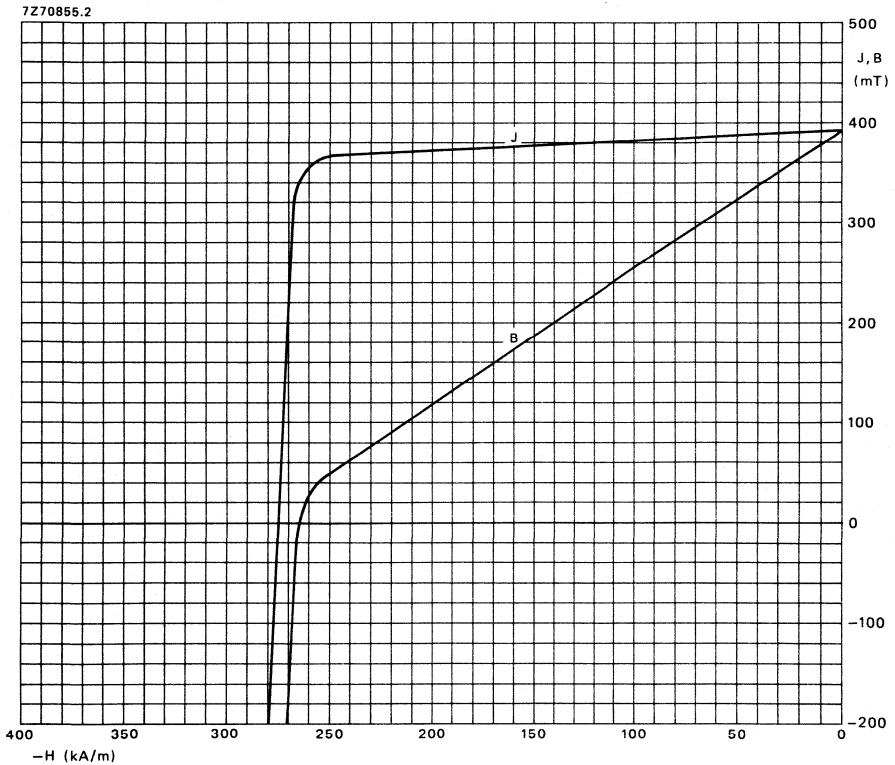

FERROXDURE 400
anisotropic ceramic material

GENERAL

This specification relates to tests carried out on test pieces made from each batch of material taken from normal production. The test piece has dimensions of approximately ϕ 35 mm x 12 mm.

Magnets manufactured from this material conform generally to this specification but, owing to the method of manufacture and to the variation in size and shape, some limits cannot always be realized, or indeed checked by measurement on the magnet. However, a minimum-flux test or similar test described in each magnet specification, can be used as a basis for performance guarantees.

COMPOSITION

Ferroxdure 400 is a strontium ferrite, the main constituent being $\text{SrFe}_{12}\text{O}_{19}$.

MAGNETIC AND ELECTRICAL PROPERTIES OF THE TEST PIECE

Temperature of the test piece is 25 ± 2 °C unless otherwise specified.

		typ.	min.	typ.	min.
Remanence	B_r	410	400 mT	4100	4000 Gs
Coercivity	H_{cB}	265	250 kA/m	3300	3100 Oe
Polarization coercivity	H_{cJ}	275	260 kA/m	3500	3300 Oe
→ Maximum BH product	$(BH)_{\max}$	31,3	29,8 kJ/m ³	3,9	3,7 MGsOe
Magnetic flux density corresponding to $(BH)_{\max}$	B_d	200	mT	2000	Gs
→ Magnetic field strength corresponding to $(BH)_{\max}$	H_d	155	kA/m	1950	Oe
Recoil permeability	μ_{rec}	1,1		1,1	
Temperature coefficient of B_r (-40 to + 200 °C)		-0,2	%/K	-0,2	%/°C
Temperature coefficient of H_{cJ} (-40 to + 200 °C)		≈0,95	kA/m/K	≈ 12	Oe/°C
Saturation field strength	H_{sat}		955 kA/m		12 000 Oe
Resistivity	ρ	10^4	Ωm	10^6	Ωcm
Curie point		450	°C	450	°C

PHYSICAL PROPERTIES

Density	typ.	$4,8 \times 10^3$ kg/m ³	(4,8 g/cm ³)
Coefficient of linear expansion (20 to 300 °C)	⊥ MA 8 and // MA 13		$\cdot 10^{-6}$ /K
Hardness (Moh's scale)	typ.	6,5	

DIRECTION OF MAGNETIZATION

Ferroxdure 400 is an anisotropic material, and has therefore a preferred direction of magnetization (Magnetic Axis), which must be shown on the magnet drawing.

QUALITY AND FINISH

The material allows magnets to be produced having a good, clean finish and appearance according to the appropriate visual limit samples.

TYPICAL DEMAGNETIZATION CURVE (25 °C)

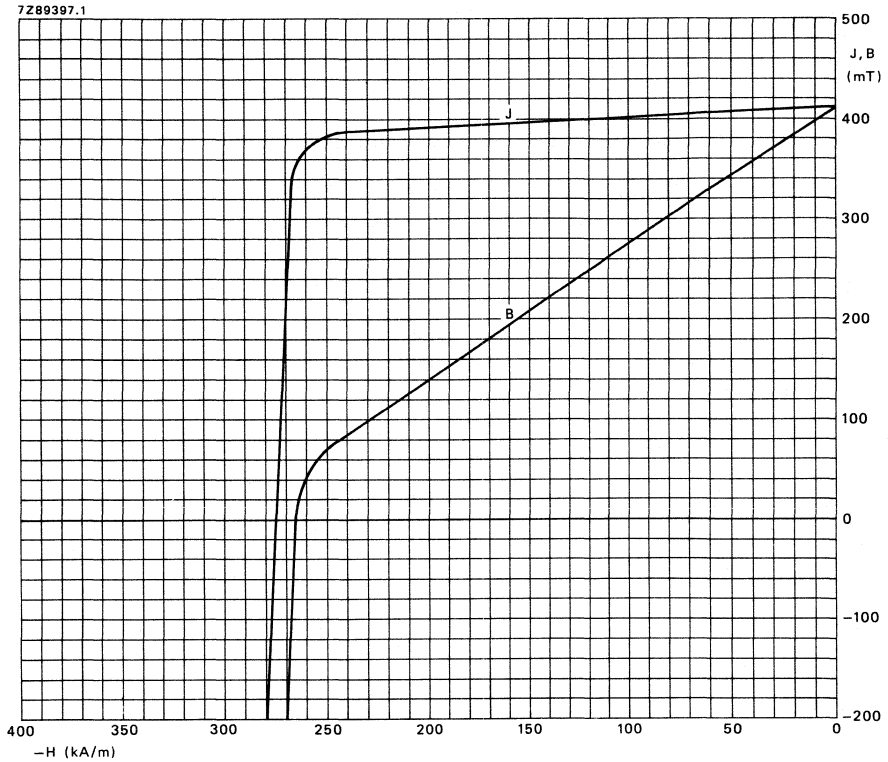

FERROXDURE 460
anisotropic ceramic material

GENERAL

This specification relates to tests carried out on test pieces made from each batch of material taken from normal production. The test piece has dimensions of approximately ϕ 35 mm x 12 mm.

Magnets manufactured from this material conform generally to this specification but, owing to the method of manufacture and to the variation in size and shape, some limits cannot always be realized, or indeed checked by measurement on the magnet. However, a minimum-flux test or similar test described in each magnet specification, can be used as a basis for performance guarantees.

COMPOSITION

Ferroxdure 460 is a strontium ferrite, the main constituent being $\text{SrFe}_{12}\text{O}_{19}$.

MAGNETIC AND ELECTRICAL PROPERTIES OF THE TEST PIECE

Temperature of the test piece is 25 ± 2 °C unless otherwise specified.

		typ.	min.	typ.	min.
Remanence	B_r	365	360 mT	3650	3600 Gs
Coercivity	H_{cB}	270	265 kA/m	3400	3300 Oe
Polarization coercivity	H_{cJ}	365	350 kA/m	4600	4400 Oe
Maximum BH product	$(BH)_{\max}$	24,8	24,1 kJ/m ³	3,1	3,0 MGsOe
Magnetic flux density corresponding to $(BH)_{\max}$	B_d	180	mT	1800	Gs
Magnetic field strength corresponding to $(BH)_{\max}$	H_d	140	kA/m	1750	Oe
Recoil permeability	μ_{rec}	1,1		1,1	
Temperature coefficient of B_r (-40 to +200 °C)		-0,2	%/K	-0,2	%/°C
Temperature coefficient of H_{cJ} (-40 to +200 °C)		$\approx 0,95$	kA/m/K	≈ 12	Oe/°C
Saturation field strength	H_{sat}		1200 kA/m		14 000 Oe
Resistivity	ρ	10^4	Ωm	10^6	Ωcm
Curie point		450	°C	450	°C

PHYSICAL PROPERTIES

Density	typ.	$4,7 \times 10^3 \text{ kg/m}^3$	$(4,7 \text{ g/cm}^3)$
Coefficient of linear expansion (20 to 300 °C)	\perp MA 8 and \parallel MA 13		$\cdot 10^{-6}/\text{K}$
Hardness (Moh's scale)	typ.	6,5	

DIRECTION OF MAGNETIZATION

Ferroxdure 460 is an anisotropic material, and has therefore a preferred direction of magnetization (Magnetic Axis), which must be shown on the magnet drawing.

QUALITY AND FINISH

The material allows magnets to be produced having a good, clean finish and appearance according to the appropriate visual limit samples.

TYPICAL DEMAGNETIZATION CURVE (25 °C)

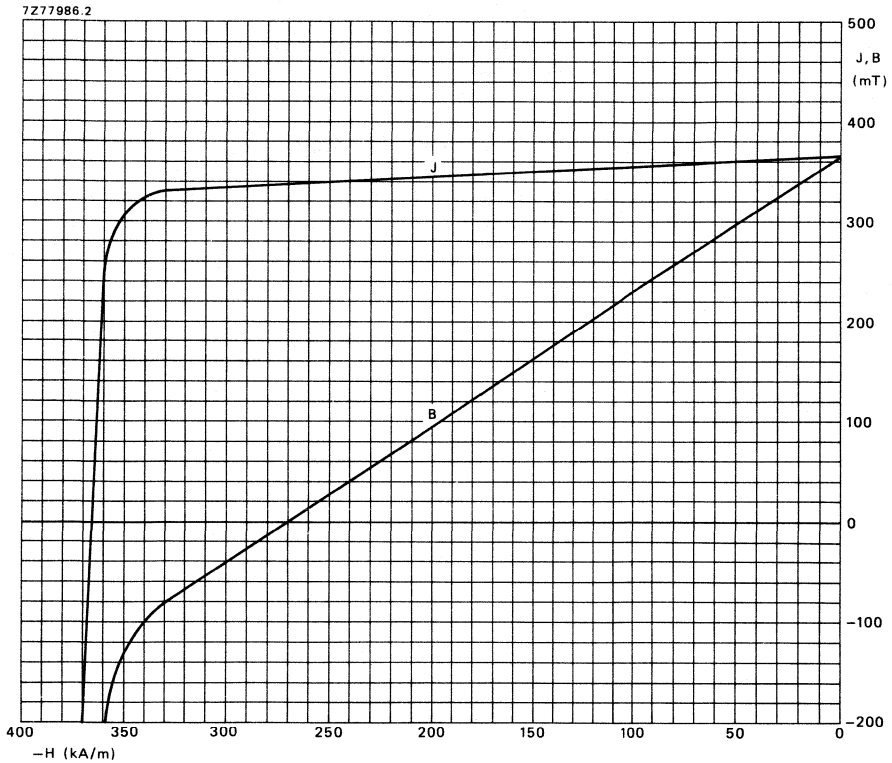

FERROXDURE 480
anisotropic ceramic material

GENERAL

This specification relates to tests carried out on test pieces made from each batch of material taken from normal production. The test piece has dimensions of approximately ϕ 35 mm x 12 mm.

Magnets manufactured from this material conform generally to this specification but, owing to the method of manufacture and to the variation in size and shape, some limits cannot always be realized, or indeed checked by measurement on the magnet. However, a minimum-flux test or similar test described in each magnet specification, can be used as a basis for performance guarantees.

COMPOSITION

Ferroxdure 480 is a strontium ferrite, the main constituent being $\text{SrFe}_{12}\text{O}_{19}$.

MAGNETIC AND ELECTRICAL PROPERTIES OF THE TEST PIECE

Temperature of the test piece is 25 ± 2 °C unless otherwise specified.

		typ.	min.	typ.	min.
Remanence	B_r	380	370 mT	3800	3700 Gs
Coercivity	H_{cB}	280	270 kA/m	3500	3400 Oe
Polarization coercivity	H_{cJ}	320	305 kA/m	4000	3800 Oe
Maximum BH product	$(BH)_{\max}$	26,8	25,5 kJ/m ³	3,4	3,2 MGsOe
Magnetic flux density corresponding to $(BH)_{\max}$	B_d	190	mT	1900	Gs
Magnetic field strength corresponding to $(BH)_{\max}$	H_d	140	kA/m	1750	Oe
Recoil permeability	μ_{rec}	1,1		1,1	
Temperature coefficient of B_r (−40 to +200 °C)		−0,2	%/K	−0,2	%/°C
Temperature coefficient of H_{cJ} (−40 to +200 °C)		≈ 0,95	kA/m/K	≈ 12	Oe/°C
Saturation field strength	H_{sat}		1115 kA/m		14 000 Oe
Resistivity	ρ	10^4	Ωm	10^6	Ωcm
Curie point		450	°C	450	°C

PHYSICAL PROPERTIES

Density	typ.	$4,7 \times 10^3$ kg/m ³	(4,7 g/cm ³)
Coefficient of linear expansion (20 to 300 °C)	⊥ MA 8 and // MA 13		$\cdot 10^{-6}/\text{K}$
Hardness (Moh's scale)	typ.	6,5	

DIRECTION OF MAGNETIZATION

Ferroxdure 480 is an anisotropic material, and has therefore a preferred direction of magnetization (Magnetic Axis), which must be shown on the magnet drawing.

QUALITY AND FINISH

The material allows magnets to be produced having a good, clean finish and appearance according to the appropriate visual limit samples.

TYPICAL DEMAGNETIZATION CURVE (25 °C)

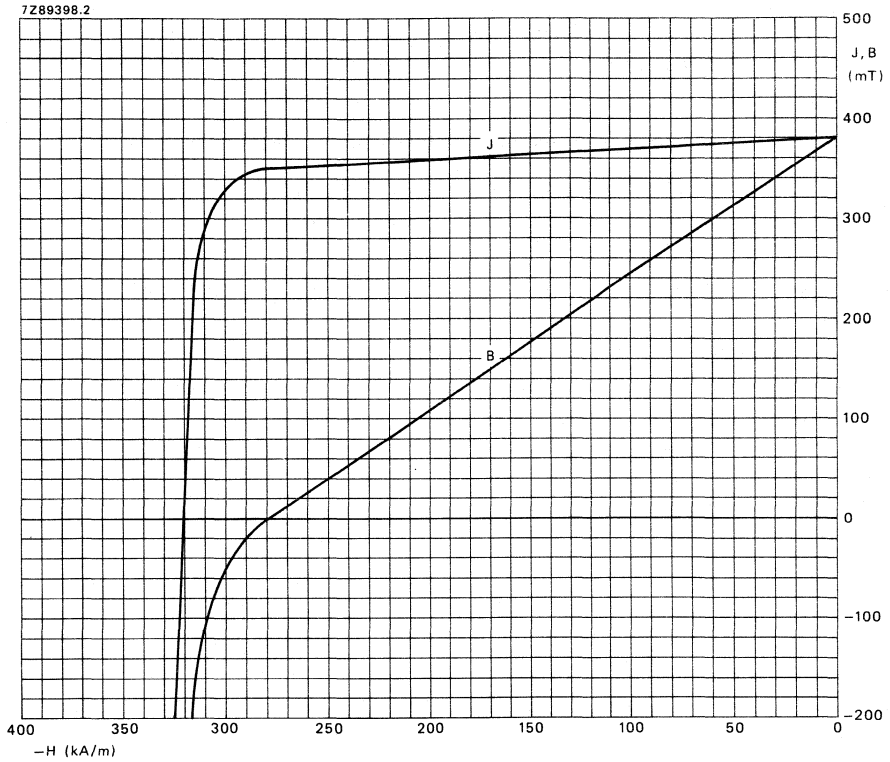

FERROXDURE 500
anisotropic ceramic material

GENERAL

This specification relates to tests carried out on test pieces made from each batch of material taken from normal production. The test piece has dimensions of approximately ϕ 35 mm x 12 mm.

Magnets manufactured from this material conform generally to this specification but, owing to the method of manufacture and to the variation in size and shape, some limits cannot always be realized, or indeed checked by measurement on the magnet. However, a minimum-flux test or similar test described in each magnet specification, can be used as a basis for performance guarantees.

COMPOSITION

Ferroxdure 500 is a strontium ferrite, the main constituent being $\text{SrFe}_{12}\text{O}_{19}$.

MAGNETIC AND ELECTRICAL PROPERTIES OF THE TEST PIECE

Temperature of the test piece is 25 ± 2 °C unless otherwise specified.

		typ.	min.		typ.	min.
Remanence	B_r	405	400	mT	4050	4000
Coercivity	H_{cB}	295	285	kA/m	3700	3600
Polarization coercivity	H_{cJ}	320	310	kA/m	4000	3900
Maximum BH product	$(BH)_{\max}$	30,5	29,8	kJ/m^3	3,8	3,7
Magnetic flux density corresponding to $(BH)_{\max}$	B_d	200		mT	2000	Gs
Magnetic field strength corresponding to $(BH)_{\max}$	H_d	150		kA/m	1900	Oe
Recoil permeability	μ_{rec}	1,1			1,1	
Temperature coefficient of B_r (-40 to +200 °C)		-0,2		%/K	-0,2	%/°C
Temperature coefficient of H_{cJ} (-40 to +200 °C)		$\approx 0,95$		kA/m/K	≈ 12	Oe/°C
Saturation field strength	H_{sat}		1100	kA/m		14 000
Resistivity	ρ	10^4		Ωm	10^6	Ωcm
Curie point		450		°C	450	°C

PHYSICAL PROPERTIES

Density	typ.	$4,8 \times 10^3$ kg/m ³	(4,8 g/cm ³)
Coefficient of linear expansion (20 to 300 °C)	\perp MA 8 and \parallel MA 13		$\cdot 10^{-6}/\text{K}$
Hardness (Moh's scale)	typ.	6,5	

DIRECTION OF MAGNETIZATION

Ferroxdure 500 is an anisotropic material, and has therefore a preferred direction of magnetization (Magnetic Axis), which must be shown on the magnet drawing.

QUALITY AND FINISH

The material allows magnets to be produced having a good, clean finish and appearance according to the appropriate visual limit samples.

TYPICAL DEMAGNETIZATION CURVE (25 °C)

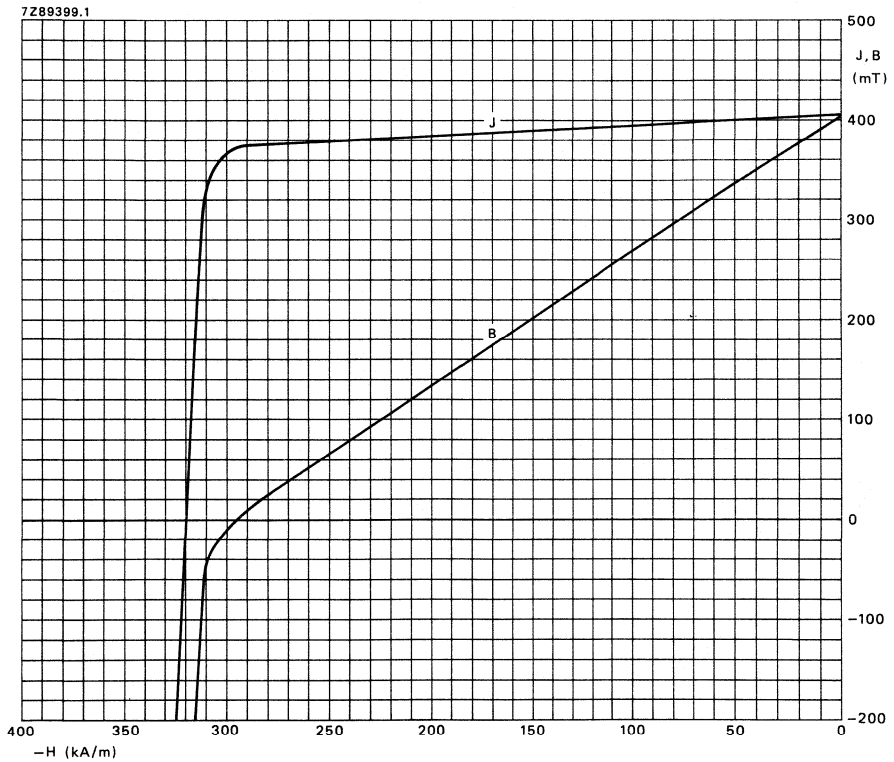

FERROXDURE 520
anisotropic ceramic material

GENERAL

This specification relates to tests carried out on test pieces made from each batch of material taken from normal production. The test piece has dimensions of approximately ϕ 35 mm x 12 mm.

Magnets manufactured from this material conform generally to this specification but, owing to the method of manufacture and to the variation in size and shape, some limits cannot always be realized, or indeed checked by measurement on the magnet. However, a minimum-flux test or similar test described in each magnet specification, can be used as a basis for performance guarantees.

COMPOSITION

Ferroxdure 520 is a strontium ferrite, the main constituent being SrFe₁₂O₁₉.

MAGNETIC AND ELECTRICAL PROPERTIES OF THE TEST PIECE

Temperature of the test piece is 25 ± 2 °C unless otherwise specified.

		typ.	min.	typ.	min.
Remanence	B _r	425	420 mT	4250	4200 Gs
Coercivity	H _{cB}	250	240 kA/m	3100	3000 Oe
Polarization coercivity	H _{cJ}	260	250 kA/m	3300	3100 Oe
Maximum BH product	(BH) _{max}	33,6	32,8 kJ/m ³	4,2	4,1 MGsOe
Magnetic flux density corresponding to (BH) _{max}	B _d	210	mT	2100	Gs
Magnetic field strength corresponding to (BH) _{max}	H _d	160	kA/m	2000	Oe
Recoil permeability	μ _{rec}	1,1		1,1	
Temperature coefficient of B _r (-40 to + 200 °C)		-0,2	%/K	-0,2	%/°C
Temperature coefficient of H _{cJ} (-40 to + 200 °C)		≈ 0,95	kA/m/K	≈ 12	Oe/°C
Saturation field strength	H _{sat}		955 kA/m		12 000 Oe
Resistivity	ρ	10 ⁴	Ωm	10 ⁶	Ωcm
Curie point		450	°C	450	°C

PHYSICAL PROPERTIES

Density	typ.	4,8 x 10 ³ kg/m ³	(4,8 g/cm ³)
Coefficient of linear expansion (20 to 300 °C)	⊥ MA 8 and // MA 13		. 10 ⁻⁶ /K
Hardness (Moh's scale)	typ.	6,5	

DIRECTION OF MAGNETIZATION

Ferroxdure 520 is an anisotropic material, and has therefore a preferred direction of magnetization (Magnetic Axis), which must be shown on the magnet drawing.

QUALITY AND FINISH

The material allows magnets to be produced having a good, clean finish and appearance according to the appropriate visual limit samples.

TYPICAL DEMAGNETIZATION CURVE (25 °C)

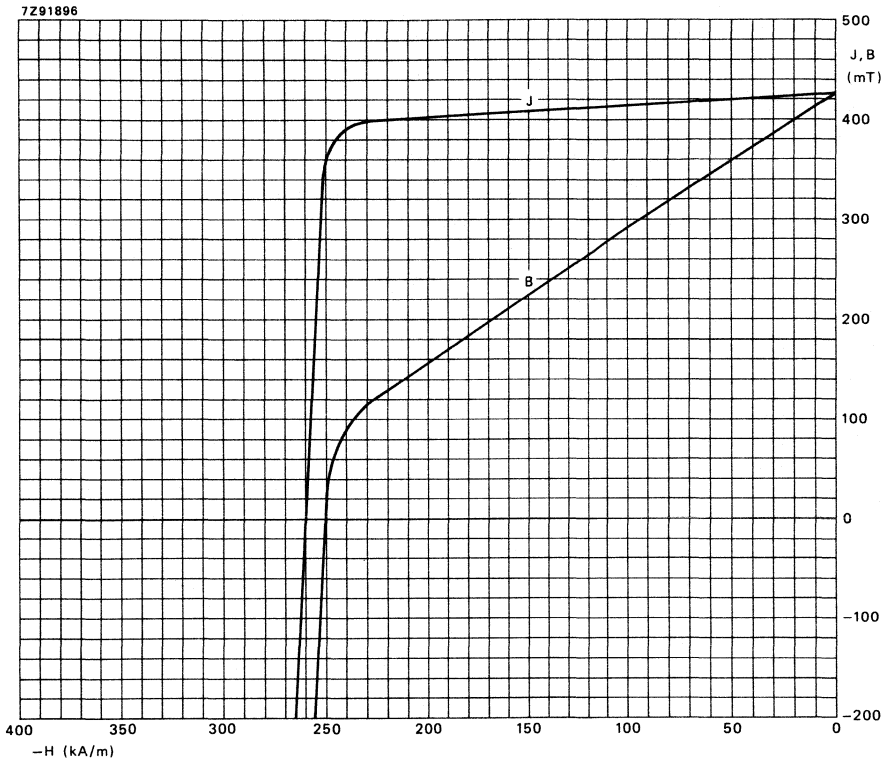

FERROXDURE 580
anisotropic ceramic material

GENERAL

This specification relates to tests carried out on test pieces made from each batch of material taken from normal production. The test piece has dimensions of approximately ϕ 35 mm x 12 mm.

Magnets manufactured from this material conform generally to this specification but, owing to the method of manufacture and to the variation in size and shape, some limits cannot always be realized, or indeed checked by measurement on the magnet. However, a minimum-flux test or similar test described in each magnet specification, can be used as a basis for performance guarantees.

COMPOSITION

Ferroxdure 580 is a strontium ferrite, the main constituent being SrFe₁₂O₁₉.

MAGNETIC AND ELECTRICAL PROPERTIES OF THE TEST PIECE

Temperature of the test piece is 25 ± 2 °C unless otherwise specified.

		typ.	min.		typ.	min.
Remanence	B _r	385	375	mT	3850	3750
Coercivity	H _{cB}	285	275	kA/m	3600	3500
Polarization coercivity	H _{cJ}	335	325	kA/m	4250	4100
Maximum BH product	(BH) _{max}	27,6	26,2	kJ/m ³	3,5	3,3
Magnetic flux density corresponding to (BH) _{max}	B _d	190		mT	1900	Gs
Magnetic field strength corresponding to (BH) _{max}	H _d	145		kA/m	1800	Oe
Recoil permeability	μ _{rec}	1,1			1,1	
Temperature coefficient of B _r (-40 to + 200 °C)		-0,2		%/K	-0,2	%/°C
Temperature coefficient of H _{cJ} (-40 to + 200 °C)		≈ 0,95		kA/m/K	≈ 12	Oe/°C
Saturation field strength	H _{sat}		1200	kA/m		15 000
Resistivity	ρ	10 ⁴		Ωm	10 ⁶	Ωcm
Curie point		450		°C	450	°C

PHYSICAL PROPERTIES

Density	typ.	4,7 x 10 ³ kg/m ³	(4,7 g/cm ³)
Coefficient of linear expansion (20 to 300 °C)	⊥ MA 8 and // MA 13		. 10 ⁻⁶ /K
Hardness (Moh's scale)	typ.	6,5	

DIRECTION OF MAGNETIZATION

Ferroxdure 580 is an anisotropic material, and has therefore a preferred direction of magnetization (Magnetic Axis), which must be shown on the magnet drawing.

QUALITY AND FINISH

The material allows magnets to be produced having a good, clean finish and appearance according to the appropriate visual limit samples.

TYPICAL DEMAGNETIZATION CURVE (25 °C)

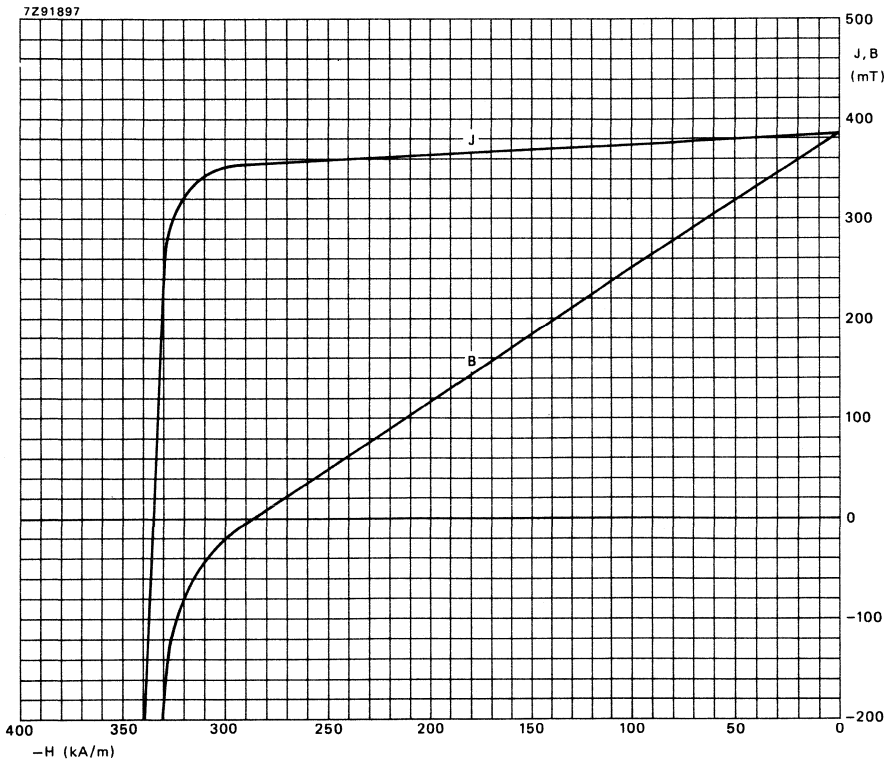

FERROXDURE MAGNET TYPE LISTS

GENERAL

The MAGNET TYPE LIST gives initial information on the main dimensions etc. of types for which tooling already exists. Choice of a type from this list eliminates the need for new tools and consequent delay in delivery. It is important to check with the supplier if the data are still valid. Frequent additions, eliminations or changes may render the survey in this Data Handbook outdated. In that case, an updated list should be consulted.

The exact mechanical and magnetic data and the correct code number (last digit) have been laid down in the MAGNET SPECIFICATIONS, which exist for each type, and which will be sent on request.

For anisotropic sintered Ferroxdure, most shapes can be supplied in ANOTHER MATERIAL GRADE than that listed, however, due to different shrinkage properties, some differences in dimensions may be expected.

For plastic-bonded Ferroxdure, all shapes can be supplied with DIFFERENT POLE PATTERNS than those listed.

For optimum results, supply of pre-magnetized magnets is not always advisable because self-demagnetization may occur due to unfavourable combinations of grade, the ratio of magnetic area to magnetic length and temperature variation.

Permanent magnets can also be ordered to your OWN DESIGN (within the limits of the material and manufacturing techniques). Our TECHNICAL ASSISTANCE on the design and application of permanent magnets is always at your disposal.

The MAGNET TYPE LIST of Ferroxdure products is divided into 6 sections:

For anisotropic sintered Ferroxdure

- section 1 - blocks
- section 2 - discs and rods (axially oriented)
- section 3 - cylinders (diametrically oriented)
- section 4 - rings (axially oriented)
- section 5 - segments

For isotropic plastic bonded Ferroxdure

- section 6 - various shapes

→ The indication S, in some cases placed after the material grade, means that the product in question has magnetic properties which deviate slightly from the basic properties of that material grade.

Some products are made in material grades which are not listed in the General Section. These grades have the following main properties (minimum values).

→ FXD370: $B_r = 380$ mT; $H_{cJ} = 230$ kA/m.
FXD375: $B_r = 370$ mT; $H_{cJ} = 260$ kA/m.

ANISOTROPIC SINTERED FERROXDURE

(section 1 – blocks)

BLOCKS

Orientation: perpendicular to a x b

Where more than one catalogue number is mentioned in the table, the first is of an unmagnetized product, the second is of a magnetized product.

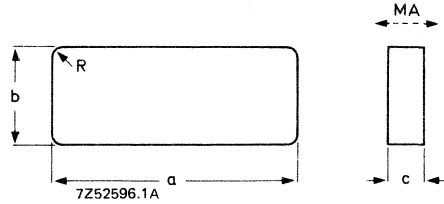

a mm	b mm	c mm	FXD	mass g	catalogue no.
12,0 ^{+ 0,1} - 0,5	8,0 ± 0,3	7,0 + 0,3	330	3,2	— 4311 021 31220
12,0 ^{+ 0,1} - 0,5	11,0 - 0,6	7,0 ± 0,1	330	4,6	4311 021 30150 4311 021 31290
13,0 ± 0,3	10,0 ± 0,3	5,0 ± 0,4	330	3,1	— 4311 021 32680
17,0 ± 0,4	10,0 ± 0,3	5,0 ± 0,4	330	4,3	— 4311 021 30980
18,0 - 0,9	15,0 - 0,7	9,0 - 0,1	330	10,8	— 4311 021 31920
20,0 ± 0,5	10,0 ± 0,3	5,0 ± 0,4	330	4,6	— 4311 021 30720
25,0 ± 0,5	11,0 ± 0,3	5,6 ± 0,5	330	7,2	4311 021 35070 —
30,0 ± 0,7	30,0 ± 0,7	8,0 ± 0,05	380 S	35,5	4322 020 67350 —
40,0 ± 1,0	21,0 ± 0,5	10,0 ± 0,5	330	41	— 4311 021 30260
40,0 ± 1,0	25,0 ± 0,75	10,0 ± 0,1	330	46	4322 020 62300 4322 020 62180
42,5 + 1,6	25,2 + 1,2	8,8 ± 0,05	300 S	40	4311 021 34650 —

FERROXDURE
MAGNET TYPE LIST

BLOCKS (continued)

a mm	b mm	c mm	FXD	mass	catalogue no.
42,5 + 1,6	25,2 + 1,2	8,8 ± 0,05	330	46	4311 021 34560 —
49,2 ± 1,2	49,2 ± 1,2	4,5 ± 0,5	330	53,5	4311 021 33630 —
50,0 ± 1,3	19,0 ± 0,5	4,9 - 0,25	330	21	4322 020 62220 4322 020 62270
50,0 ± 1,3	19,0 ± 0,5	6,1 ± 0,1	330	26	4322 020 62190 4322 020 62210
51,5 + 3,0	51,5 + 3,0	6,0 ± 0,1	380	109	4322 020 67360 —
51,5 + 3,0	51,5 + 3,0	10,0 ± 0,1	330 S	123	4322 020 67340 —
60,0 ± 1,5	20,0 ± 0,6	15,0 ± 0,5	330	85	— 4311 021 35880
64,0 ± 1,5	32,0 ± 0,7	20,0 ± 0,1	330	192	4311 021 36050 —
75,0 ± 2,0	50,0 ± 1,5	19,9 ± 0,1	330	353	4322 020 62310 4322 020 62320
100,0 ± 2,5	75,0 ± 1,9	25,4 ± 0,2	330	900	4311 021 32330 4311 020 32910
131,0 ± 3,0	51,0 ± 1,5	15,0 ± 0,2	330	460	4322 020 62470 —
131,0 ± 3,0	51,0 ± 1,5	17,5 ± 0,2	330	550	4322 020 62140 4322 020 62480
150,0 ± 3,7	100,0 ± 2,5	25,4 ± 0,2	370	1800	4311 021 33050 4311 021 33150
150,0 ± 3,7	100,0 ± 2,5	25,4 ± 0,2	330	1800	4322 020 62330 4322 020 62340

ANISOTROPIC SINTERED FERROXDURE
(section 2 – discs and rods)

DISCS AND RODS

Orientation: axial
Where more than one catalogue number is mentioned, the first is of an unmagnetized product, the second is of a magnetized one.

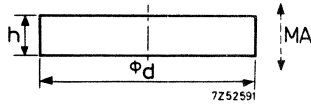

d mm	h mm	FXD	mass g	catalogue number
10 ± 0,5	10 ± 0,2	330 S	3,8	— 4322 020 61020
12 ± 0,3	6 ± 0,25	300	3,5	— 4322 020 62540
12,1 ± 0,3	6 ± 0,4	330	3,3	— 4311 021 33690
29,25 ± 0,75	7,2 ± 0,2	330	22,6	4311 021 30240 4311 021 31390
29,25 ± 0,75	10,5 ± 0,5	330	33	— 4311 021 32570
39 ± 1	7,0 ± 0,1	300	39,5	4311 021 34710 —
45 ± 1	9,0 ± 0,1	330	67,7	4311 021 34870 —
53 ± 1,3	9,0 ± 0,1	300	94	4311 021 34720 —



ANISOTROPIC SINTERED FERROXDURE
(section 3 – cylinders)

CYLINDERS

Orientation: diametrical

Where more than one catalogue number is mentioned, the first is of an unmagnetized product, the second is of a magnetized one.

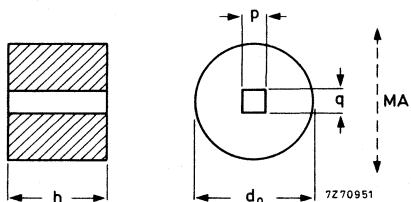

d_o mm	$p \times q$ mm	h mm	FXD	mass g	catalogue number
$14,7 \pm 0,03$	$4,5 \pm 0,3$ x $3,9 \pm 0,3$	$8 \pm 0,1$	380 S	6,2	4203 014 80280 —
$14,7 \pm 0,03$	$3,9 \pm 0,3$ x $3,5 \pm 0,3$	$25,5 \pm 0,1$	250*	20	4203 014 80120 —
$18,3 \pm 0,03$	$5,5 \pm 0,2$ x $4,8 \pm 0,2$	$30 \pm 0,1$	250*	30	4203 014 80040 —

* Modified FXD330 with $B_r = 330$ mT.

$H_{cB} = 200$ kA/m and $H_{cJ} = 210$ kA/m.

ANISOTROPIC SINTERED FERROXDURE
(section 4)

RINGS

Orientation: axial

These are mainly for loudspeakers.

Unmagnetized versions only are listed, magnetized products from this range are also available. Some loss of performance can be expected when using pre-magnetized rings. The extent of this is dependent on dimensions and storage conditions. Please ask for details.

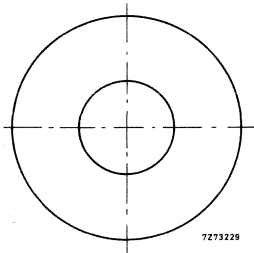
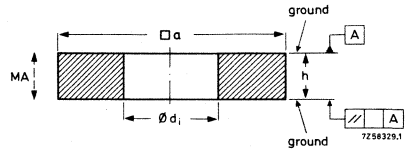
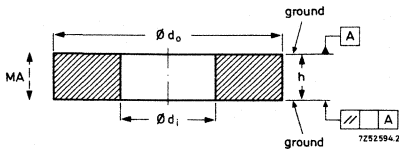

$r = \pm 0,5 \text{ mm}$

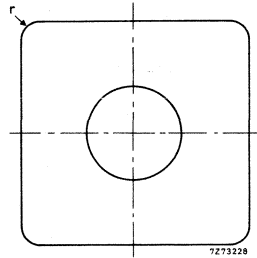

FERROXDURE
MAGNET TYPE LIST

RINGS (continued)

d_o mm	d_i mm	h mm	FXD	mass g	catalogue number
$28,5 \pm 0,7^*$	$12,9 \pm 0,4$	$5,0 \pm 0,15$	300	17,0	4311 021 35000
$30,0 \pm 0,75$	$16,0 \pm 0,4$	$5,0 \pm 0,1$	300	12,4	4311 021 37270
$36,0 \pm 0,8$	$18,0 \pm 0,5$	$6,0 \pm 0,1$	300	23,0	4311 021 35210
$36,0 \pm 0,8$	$18,0 \pm 0,5$	$8,0 \pm 0,1$	300	30,0	4311 021 36840
$40,0^{+1,3}_{-0,7}$	$22,0 \pm 0,5$	$9,0 \pm 0,1$	300	39,0	4311 021 36610
$45,0 \pm 1,0$	$22,0 \pm 0,6$	$8,0 \pm 0,1$	300	47,0	4311 021 35220
$45,0 \pm 1,0$	$22,0 \pm 0,6$	$9,0 \pm 0,1$	300	53,0	4311 021 36620
$51,0 \pm 1,2$	$24,0 \pm 0,6$	$9,0 \pm 0,1$	300	70,0	4311 021 36650
$53,0 \pm 1,2$	$30,0 \pm 0,7$	$8,0 \pm 0,1$	300	59,0	4311 021 35740
$55,0 \pm 1,2$	$24,0 \pm 0,6$	$8,0 \pm 0,1$	300	75,0	4311 021 36670
$55,0 \pm 1,2$	$24,0 \pm 0,6$	$12,0 \pm 0,1$	300	113,0	4311 021 35910
$60,0 \pm 1,5$	$24,0 \pm 0,6$	$9,0 \pm 0,1$	300	105,0	4311 021 35920
$60,0 \pm 1,5$	$24,0 \pm 0,6$	$10,0 \pm 0,1$	300	116,0	4311 021 36710
$60,0 \pm 1,5$	$24,0 \pm 0,6$	$13,0 \pm 0,1$	300	151,0	4311 021 36730
$60,0 \pm 1,5$	$30,0 \pm 0,7$	$10,0 \pm 0,1$	300	104,0	4311 021 36760
$60,0 \pm 1,5$	$30,0 \pm 0,7$	$13,0 \pm 0,1$	300	136,0	4311 021 36770
$72,0 \pm 1,5$	$32,0 \pm 0,7$	$10,0 \pm 0,1$	300	160,0	4311 021 37410
$72,0 \pm 1,5$	$32,0 \pm 0,7$	$12,0 \pm 0,1$	300	192,0	4311 021 35760
$72,0 \pm 1,5$	$32,0 \pm 0,7$	$15,0 \pm 0,1$	300	240,0	4322 020 60240
$72,0 \pm 1,5$	$32,0 \pm 0,7$	$20,0 \pm 0,1$	300	320,0	4311 021 35770
$84,0 \pm 1,8$	$32,0 \pm 1,6$	$15,0 \pm 0,1$	300	345,0	4311 021 33660
$84,0 \pm 2,1$	$42,0 \pm 1,1$	$15,0 \pm 0,15$	300	306,0	4322 020 60980
$90,0 \pm 1,8$	$36,0 \pm 0,9$	$17,0 \pm 0,15$	300	448,0	4322 020 60280
$90,0 \pm 1,8$	$42,0 \pm 1,1$	$17,0 \pm 0,15$	300	415,0	4322 020 60750
$90,0 \pm 1,8$	$42,0 \pm 1,1$	$18,0 \pm 0,15$	300	439,0	4311 021 35780
$90,0 \pm 1,8$	$42,0 \pm 1,1$	$21,0 \pm 0,15$	300	520,0	4322 020 60880

* □ square magnet.

RINGS (continued)

d_o mm	d_i mm	h mm	FXD	mass g	catalogue number
102,0 ± 2,5	42,0 ± 1,1	17,0 ± 0,2	300	565,0	4311 021 34910
102,0 ± 3,0	51,0 ± 1,5	10,0 ± 0,15	300	300,0	4322 020 60300
102,0 ± 3,0	51,0 ± 1,5	14,0 ± 0,15	300	420,0	4322 020 60310
102,0 ± 3,0	51,0 ± 1,5	18,0 ± 0,15	300	540,0	4311 021 33900
102,0 ± 3,0	51,0 ± 1,5	20,0 ± 0,2	300	600,0	4311 021 35790
102,0 ± 3,0	57,0 ± 1,5	12,0 ± 0,15	300	330,0	4322 020 60790
102,0 ± 3,0	57,0 ± 1,5	17,0 ± 0,15	300	470,0	4322 020 60930
110,0 ± 3,0	45,0 ± 1,1	18,0 ± 0,15	300	698,0	4311 021 35800
110,0 ± 3,0	57,0 ± 1,5	20,0 ± 0,15	300	681,0	4311 021 35810
121,0 ± 3,6	42,0 ± 1,1	20,0 ± 0,15	300	991,0	4311 021 35820
121,0 ± 3,6	57,0 ± 1,7	12,0 ± 0,2	300	527,0	4322 020 60320
121,0 ± 3,6	57,0 ± 1,7	17,5 ± 0,2	300	767,0	4322 020 60570
121,0 ± 3,6	57,0 ± 1,7	20,0 ± 0,15	300	876,0	4311 021 35830
121,0 ± 3,6	64,0 ± 1,7	20,0 ± 0,2	300	811,0	4322 020 60900
134,0 ± 4,0	57,0 ± 1,7	20,0 ± 0,2	300	1132,0	4322 020 60020
184,0 ± 5,5	73,0 ± 2,2	18,5 ± 0,2	300	2032,0	4322 020 60350
224,0 ± 5,0	122,0 ± 3,0	23,0 ± 0,2	300	3124,0	4311 021 35840

ANISOTROPIC SINTERED FERROXDURE

(section 5-segments)

SEGMENTS FOR MOTORS

Basic shapes

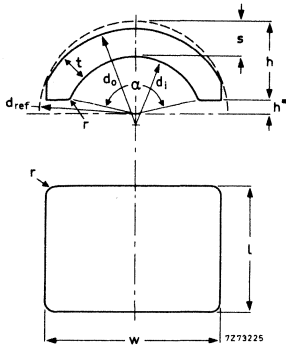

A
Concave-convex

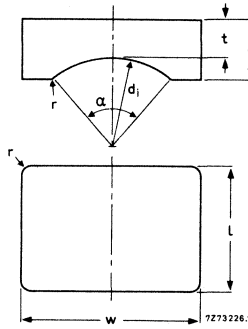

B
Flat-concave

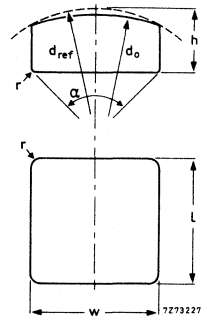

C
Flat-convex

Note: The diameter d_{ref} corresponds with the maximum internal diameter of the stator housing. Most segments have an outer diameter $\geq d_{ref}$. In this way, two-point contact with the stator housing is obtained, avoiding rocking of the segment.

Variants on the feet of shapes A and B



Variants on the inner radii
of shapes A and B

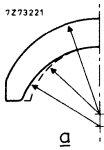

"Divergence"

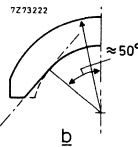

Tangential flats
inside

Variants on the outer radii
of shapes A and C

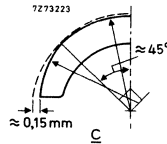

Contact points
within 90°

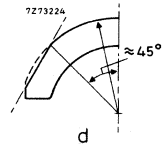

Outside flats

Addition of slots

In principle, all basic shapes can be provided with slots (u).

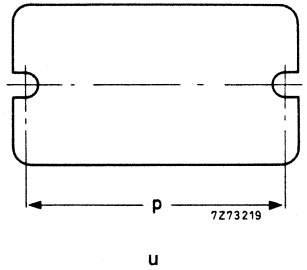

Gauge

All motor segments produced have to pass through a gauge which defines the maximum space that the segment may occupy (left figure) and in which d_o corresponds with minimum stator diameter and d_i with maximum rotor diameter + 2x minimum air gap. The main dimensions of the gauges are given in the tables. Where the centre point of the inner gauge diameter is below that of the outer gauge diameter (see right figure), the "ecc." column gives the (negative) value for this eccentricity, which corresponds with variant "a" on the previous page.

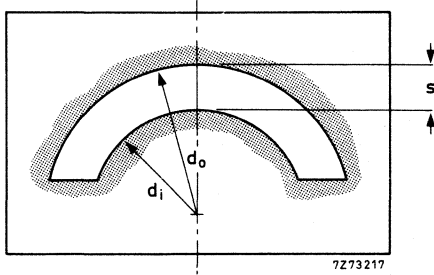

"Go" gauge

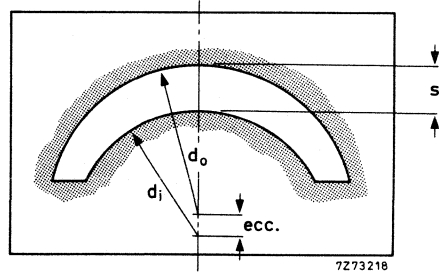

"Go" gauge for variant "a"

Legend

- or. = orientation
- p = parallel orientation
- r = radial orientation
- m = mass

Note: In the catalogue number column, the first catalogue number is for an unmagnetized segment; the second is for a magnetizing segment, S-pole inside; the third is for a magnetized segment, N-pole inside.

FERROXDURE
MAGNET TYPE LIST

Concave-convex segments

gauge				segment										
d _o mm	d _i mm	ecc. mm	s mm	d _o mm	d _i mm	l mm	w mm	h, h _m mm	t mm	α deg	shape or.	FXD	m g	catalogue no.
28.0	20.2	-	3.9	28.0	20.2	15.0 +0.4 -0.4	26.0 +0.5 -0.5	10.2	3.8 -0.5	140	A2C R	330	7.3	4311 021 35110
28.0	20.2	-	3.9	28.0	20.2	24.0 +0.4 -0.6	26.0 +0.5 -0.5	10.2	3.8 -0.5	140	A2C R	330	11.7	4311 021 33500
28.0	21.8	-	3.1	28.0	21.8	18.0 +0.5 -0.5	23.0 +0.3 -0.3	8.5 +0.4 -0.4	-	120	A2D R	330	6.3	4313 020 72960
30.0	21.8	-	4.1	30.0	21.8	18.0 +0.5 -0.5	25.85 +0.65 -0.65	8.5 +0.25 -0.25	-	120	A2C R	330	9.1	4311 021 32050
30.0	21.8	-	4.1	30.0	21.8	26.0 +0.55 -0.55	28.0 +0.65 -0.65	12.1 +0.4 -0.4	4.0 -0.4	150	A2C R	480	16.0	4311 021 35560
31.9	23.8	-	4.05	31.9	24.0	20.0 +0.5 -0.5	29.0 +0.5 -0.5	11.6 +0.3 -0.3	3.9 -0.4	140	A2C R	330	11.9	4311 021 34420
31.9	23.8	-	4.05	31.9	24.0	26.0 +0.6 -0.4	29.0 +0.5 -0.5	11.6 +0.3 -0.3	3.9 -0.4	140	A2C R	330	15.0	4311 021 33490
36.84	-	-	5.42	36.84	26.0	30.0 +1.0 -1.0	32.0 +0.8 -0.8	12.0 +0.3 -0.3	5.3 -0.4	120	A1C R	330	26.0	4311 021 35100
37.0	27.0	+0.1	4.9	37.0	27.0	30.0 +0.7 -0.7	30.0 +0.5 -0.5	11.8 +0.4 -0.4	4.8 -0.4	125	A2C R	330	22.5	4311 021 33510
38.1	-	-	4.5	38.1	30.0	40.0 +1.0 -1.1	34.0 +0.6 -0.6	13.4 +0.4 -0.4	4.1 =>	135	A1C R	400	32.0	4311 021 36620
38.1	-	-	4.65	38.1	28.8	40.6 +0.5 -2.0	34.0 +0.5 -0.5	13.3 +0.4 -0.5	4.55 -0.4	135	A3C R	330	32.0	4311 021 32500

gauge				segment											
d ₀ mm	d _j mm	ecc. mm	s mm	d ₀ mm	d _j mm	l mm	w mm	h, h ₁ mm	t mm	α deg	shape	or.	FXD	m g	catalogue no.
38.1	28.8	-	4.65*	38.1	28.8	+0.6 22.0 -0.6	+1.0 33.5 -0.25	+0.25 13.4 -0.25	4.55 -0.4	135	A1C	R	380	20.0	4313 020 72930
38.1	28.8	-	4.65*	38.1	28.8	+0.6 25.0 -0.6	+0.5 34.0 -0.5	+0.25 13.4 -0.25	4.55 -0.4	135	A1B	R	380	22.0	4313 020 72830
38.1	28.8	-	4.65*	38.1	28.8	+0.5 30.0 -1.0	+0.85 34.0 -0.85	+0.5 13.4 -0.4	4.55 -0.4	135	A3C	R	330	25.0	4311 021 34390
42.8	32.8	-0.2	5.2*	42.8	32.8	+0.8 32.0 -0.8	+0.6 39.0 -0.6	16.0 -1.0	4.9 -0.4	140	A1BC	R	330	35.0	4311 021 32150
44.1	-	-	5.8*	44.3	32.6	+1.0 47.0 -1.0	33.5 -1.0	+0.4 11.6 -0.4	=> 5.3	100	A2C	R	380	43.5	4311 021 35580
44.1	-	-	5.8*	44.3	32.6	+1.0 47.0 -1.0	33.5 -1.0	+0.4 11.6 -0.4	=> 5.3	100	A2C	R	330	43.0	4311 021 35550
44.2	32.6	-	5.8*	44.2	32.6	+0.7 28.7 -0.7	+0.5 38.0 -0.5	+0.5 16.1 -0.5	5.7 -0.5	140	A2C	R	330	33.5	4311 021 32460
45.6	-	-	7.3*	46.0	31.2	45.0 -2.2	+1.0 40.0 -1.0	+0.4 17.0 -0.4	7.1 -0.4	135	A1C	R	380	68.0	4311 021 35180 4311 021 35450 4311 021 35460
46.0	34.2	-	5.9*	46.1	34.2	45.0 -2.2	+1.0 40.0 -1.0	+0.4 15.8 -0.4	5.8 -0.4	135	A1BC	R	380	55.0	4311 021 35010
46.07	38.8	-2.80	6.44*	46.2	38.8	45.0 -1.8	+0.65 33.0 -0.65	+0.4 11.0 -0.4	6.4 -0.46	95	A2C	R	380	41.5	4311 021 34470
46.1	-	-	5.8*	46.2	38.0	+0.75 29.0 -0.75	+0.6 40.0 -0.6	+0.4 15.8 -0.4	5.7 -0.4	130	A1BC	R	380	35.0	4311 021 35200

FERROXDURE
MAGNET TYPE LIST

Concave-convex segments (continued)

gauge					segment										
d _o mm	d _i mm	ecc. mm	s mm	d _o mm	d _i mm	l mm	w mm	h, h [■] mm	t mm	α deg	shape	or.	FXD	m g	catalogue no.
46.1	36.0	0.55	5.6	46.1	36.0	36.0	+0.6 40.0 -0.6	+0.4 15.8 -0.4	5.5 -0.4	125	A1C	R	380	42.0	4311 021 36920
46.26	33.28	-	6.48	NOM 46.1	NOM 33.68	+1.91 30.79	38.64	11.27 7.37	=	5.81	A1	R	330	38.0	4313 020 72660
46.3	34.3	-	6.0	46.4	34.3	+0.6 35.0 -1.0	+0.6 40.0 -0.6	+0.4 16.0 -0.4	5.9 -0.4	130	A1C	R	380	45.0	4311 021 33700
47.27	34.34	-	6.46	47.43	NOM 35.0	+2.0 49.8	41.4	-	=	5.9	A2BC	R	380	67.0	4313 020 72710
47.72	33.88	-	6.92	NOM 48.2	NOM 34.6	+2.6 41.98	+1.8 35.0	+1.0 9.8	6.82 -0.49	130	A1	R	380	50.0	4313 020 72850
49.0	35.8	-	6.6	49.0	35.8	+1.0 22.0 -1.0	+1.0 36.0 -1.0	+0.5 13.5 -0.5	6.5 -0.4	105	A3	R	330	26.5	4311 021 33280
49.0	35.8	-	6.6	49.0	35.8	+1.0 38.5 -1.0	+1.0 36.0 -1.0	+0.5 13.5 -0.5	6.5 -0.4	105	A3	R	330	45.0	4311 021 32510
49.0	35.8	-	6.6	49.0	35.8	+1.0 45.0 -1.0	+1.0 36.0 -1.0	+0.5 13.5 -0.5	6.5 -0.4	105	A3	R	330	54.0	4311 021 33530
53.0	-	-	6.3	53.1	40.4	+1.0 45.0 -1.0	+0.5 47.5 -0.5	18.7 -0.5	NOM 5.8	135	A1BD	R	370	70.0	4311 021 35440
53.1	-	-	5.95	53.2	42.6	+1.0 45.0 -1.0	+0.9 46.0 -0.9	+0.3 18.0 -0.3	=	130	A1C	R	5 480	63.5	4311 021 37050
53.1	41.6	-0.25	6.0	53.2	41.6	+0.95 38.0 -0.95	+1.2 48.8 -1.2	+0.5 19.2 -0.5	5.8 -0.4	140	A1BD	R	370	56.0	4311 021 34660

gauge				segment											
d _o mm	d _i mm	ecc. mm	s mm	d _o mm	d _i mm	l mm	w mm	h, h ₁ mm	t mm	α deg	shape	or.	FXD	m g	catalogue no.
53.15	41.0	0.08	6.0	53.2	41.0	+0.6 35.0 -1.0	+0.9 46.0 -0.9	+0.4 16.3 -0.4	5.9 -0.4	120	A1C	R	380	49.0	4311 021 33570
53.3	40.84	-	6.23	53.4	41.24	+2.0 44.0	+2.0 45.0	+1.0 8.53	6.17 -0.4	120	A1C	R	330	64.6	4313 020 72670
54.61	40.84	-	6.88	54.74	41.24	+1.3 22.0	+3.0 46.5	+1.0 8.53	6.8 -0.5	130	A1C	R	330	37.6	4313 020 72560
55.1	-	-	7.1	55.12	44.0	+1.0 37.0 -1.0	+1.5 51.0 -1.0	+0.25 19.2 -0.25	=> 6.6	135	A1C	R	S 380	69.0	4311 021 37220
55.1	-	-	7.1	55.12	44.0	+1.1 45.3 -1.1	+1.5 51.0 -1.0	+0.25 19.2 -0.25	=> 6.6	135	A1C	R	400	85.0	4311 021 37230
55.2	-	-	5.8	55.2	43.6	+1.0 40.0 -1.0	+1.5 49.5	+0.25 18.75 -0.25	=> 5.3	130	A2C	R	480	60.0	4311 021 37340
55.2	-	-	5.8	55.2	43.6	+1.0 50.0 -1.0	+1.5 49.5	+0.25 18.75 -0.25	=> 5.3	130	A2C	R	480	75.0	4311 021 37330
55.35	43.72	-	5.81	55.66	44.12	+1.9 37.15	=> 50.0	-	5.7 -0.4	135	A2BC	R	480	58.0	4311 021 34400
55.4	43.6	-	5.9	55.4	43.6	+1.0 40.0 -1.0	+1.2 49.0 -1.2	+0.25 18.6 -0.25	5.8 -0.4	130	A1BC	R	375	54.0	4311 021 34540
55.9	43.2	-	6.35	56.04	43.6	+2.0 38.0	+2.0 47.0	+0.5 8.85	=> 5.75	130	A1C	R	330	62.0	4313 020 72440
55.9	43.2	-	6.35	56.04	43.6	+2.0 38.0	+2.0 47.0	+0.5 8.85	=> 5.75	130	A1C	R	380	64.0	4313 020 72790

FERROXDURE
MAGNET TYPE LIST

Concave-convex segments (continued)

gauge										segment									
d _o mm	d _i mm	ecc. mm	s mm	d _o mm	d _i mm	l mm	w mm	h, h _h mm	t mm	α deg	shape	or.	FXD	m g	catalogue no.				
56.06	43.4	-	6.33*	56.18	43.6	42.0 41.0	42.5 47.0	11.0 18.5	6.2 -0.6	130	A1C	R	380	63.0	4313 020 72840				
56.06	43.4	-	6.33*	56.18	43.6	42.0 41.0	42.5 47.0	11.0 18.5	6.2 -0.6	130	A1C	R	330	63.0	4313 020 72850				
56.06	43.6	-0.1	6.33*	56.18	43.6	35.0 -0.7	41.0 50.0	19.0 -0.25	6.2 -0.4	130	A1C	R	330	59.0	4311 021 31880				
56.06	43.6	0.1	6.33*	56.18	43.6	39.0 -1.0	46.5	19.0 -0.4	6.2 -0.6	130	A1	R	5 270	59.0	4313 020 72970				
56.06	43.6	-0.1	6.33*	56.16	43.6	45.0 -1.0	45.0	19.0 -0.5	6.2 -0.6	130	A1	R	330	75.0	4311 021 32520				
56.2	38.2	-	9.0*	57.0	40.6	21.0 -0.5	41.0 44.0	16.0 -0.5	8.6 -0.6	90	A1D	R	330	37.0	4311 021 31950 4311 021 31960 4311 021 31970				
57.9	40.4	-	8.75*	58.0	40.4	20.0 -0.5	51.0	20.3	-	125	A1BC	R	330	45.0	4311 021 32280				
57.9	40.4	-	8.75*	58.0	40.4	31.0 -0.75	51.0	20.3	-	125	A1BC	R	330	70.0	4311 021 34640				
57.9	40.4	-	8.75*	58.0	40.4	35.0 -0.9	51.0	20.3	-	125	A1BC	R	330	79.0	4311 021 33640				
57.9	40.4	-	8.75*	58.0	40.4	40.0 -1.0	52.0	20.3	-	125	A1BC	R	370	92.0	4311 021 34210				
57.9	40.4	-	8.75*	58.0	40.4	45.0 -1.1	51.0	20.3	-	125	A1BC	R	330	103.0	4311 021 35480				

gauge					segment										
d ₀ mm	d _j mm	ecc. mm	s mm	d ₀ mm	d _j mm	l mm	w mm	h, h _m mm	t mm	α deg	shape	or.	FXD	m g	catalogue no.
58.0	-	-	6.6	58.0	>= 45.0	+0.75 30.0 -0.75	+1.0 52.0 -1.3	20.3 -1.0	6.5 -0.4	130	A1C	R	330	55.0	4311 021 33820 4311 021 33830
58.0	40.6	-	8.7	58.0	+0.6 40.6	+0.5 21.0 -0.5	+1.0 44.0 -1.0	+0.5 16.0 -0.5	8.6 -0.6	90	A1	R	330	37.0	4311 021 33880 4311 021 33890 4311 021 33900 4311 021 33910 4311 021 33920 4311 021 33930 4311 021 33940 4311 021 33950
58.3	40.6	-0.15	8.7	58.3	>= 40.6	+0.5 21.0 -0.5	+1.0 44.0 -1.0	+0.5 16.0 -0.5	8.6 -0.6	90	A1	R	330	39.0	4311 021 34250 4311 021 34260 4311 021 34270 4311 021 34280 4311 021 34290 4311 021 34300
58.4	42.12	-	8.14	58.52	42.6	+1.0 20.0 -0.6	+1.2 51.6 -1.2	+0.7 21.5 -0.7	7.9 -0.4	160	A3	R	330	41.0	4311 021 35360 4311 021 35370 4311 021 35380 4311 021 35390 4311 021 35400
58.4	42.12	-	8.14	58.52	NOM 42.6	+1.6 29.8	+3.3 50.4	+1.4 7.0	7.9 -0.4	160	A3	R	330	70.0	4313 020 72460
58.4	42.12	-	8.14	58.52	>= 42.6	+1.0 36.0 -0.6	+0.5 51.6 -1.0	21.5 -0.6	7.9 -0.4	140	A3C	R	330	79.0	4311 021 34320 4311 021 34330 4311 021 34340
58.4	43.3	-	7.55	58.4	>= 43.3	+0.5 20.0 -0.5	+1.2 51.6 -1.2	+0.4 21.5 -0.4	7.35 -0.4	140	A1C	R	330	42.0	4311 021 36930
58.4	44.6	-0.3	7.2	58.4	>= 44.6	+2.0 40.8	+2.0 53.0	+1.0 21.2	7.2 -0.4	140	A1	R	5 400	80.0	4304 170 05090
58.4	44.6	-0.3	7.2	58.4	>= 44.6	+2.0 40.8	+2.0 53.0	+1.0 21.2	7.2 -0.4	140	A1	R	370	80.0	4322 010 81970
63.5	50.62	-	6.44	63.5	>= 51.0	+1.6 27.2	+1.0 56.5	+1.0 21.0	< 6.25	140	A1	R	330	53.0	4322 020 61630 4311 021 31610 4311 021 31620
63.5	50.62	-	6.44	63.5	>= 51.0	+1.0 31.0 -1.0	+0.5 57.0 -0.5	+0.5 21.5 -0.5	< 6.25	140	A1	R	380	60.0	4311 021 33560

FERROXDURE
MAGNET TYPE LIST

Concave-convex segments (continued)

segment														
gauge					segment									
d _o mm	d _i mm	ecc mm	s mm	d _o mm	d _i mm	l mm	w mm	h, h _m mm	t mm	α deg	shape or.	FXD	m g	catalogue no.
66.75	52.89	-	6.93	* +0.38 * 67.02	> 52.94	+1.52 24.64	+3.04 57.4	+1.51 9.66	<= 6.93	135	A1	R	330	4313 020 72180
66.75	52.89	-	6.93	* +0.38 * 67.02	=> 52.94	+1.6 37.8	=> 57.4	+1.52 9.65	<= 6.93	135	A1	R	330	4313 020 72170
70.06	53.7	-	8.18	* > * 70.18	=> 53.7	+0.8 35.0 -0.8	+1.5 60.0 -1.5	+0.7 24.0 -0.7	8.05 -0.6	130	A1C	R	S 380	4311 021 33960
70.06	53.7	-	8.18	* > * 70.18	=> 53.7	+1.0 40.0 -1.0	+1.5 60.0 -1.5	+0.7 24.0 -0.7	8.05 -1.15	130	A1C	R	330	4311 021 35500 4311 021 35510
70.06	53.7	-	8.18	* > * 70.18	=> 53.7	+1.0 40.0 -1.0	+1.2 60.0 -1.2	+0.4 24.0 -0.4	8.05 -0.6	130	A3	R	330	4311 021 35490
70.06	53.7	-	8.18	* > * 70.18	=> 53.7	+1.0 40.0 -1.0	+2.5 60.0	+0.35 24.0	8.05 -1.15	130	A1	R	330	4311 021 32060
70.06	53.7	-	8.18	* > * 70.18	=> 53.7	+1.0 40.0 -1.0	+1.5 60.0 -1.5	+0.7 24.0 -0.7	8.05 -0.6	130	A1C	R	330	4311 021 32070
70.06	53.7	-	8.18	* > * 70.18	=> 53.7	+1.0 40.0 -1.0	+1.5 60.0 -1.5	+0.7 24.0 -0.7	8.05 -1.15	130	A1C	R	370	4311 021 33240
70.06	53.7	-	8.18	* > * 70.18	=> 53.7	+1.0 50.0 -1.0	+1.5 60.0 -1.5	+0.7 24.0 -0.7	8.05 -0.6	130	A1	R	330	4311 021 31940
70.10	55.04	-	7.53	* > * 70.3	=> 55.6	+2.0 36.75	+2.6 62.3	+0.89 11.39	=> 6.9	130	A1C	R	330	4313 020 72760
70.10	55.04	-	7.53	* > * 70.3	=> 55.6	+2.0 44.0	+2.6 62.3	+0.89 11.39	<= 6.9	130	A1C	R	330	4313 020 72800

gauge				segment											
d _o mm	d _i mm	ecc. mm	s mm	d _o mm	d _i mm	l mm	w mm	h, h ₁ mm	t mm	α deg	shape	or.	FXD	m g	catalogue no.
70.10	55.04	-	7.53*	70.3	55.6	+2.0 44.0	+2.6 62.3	+0.89 X 11.39	<=	130	A1C	R	380	109.0	4313 020 72820
70.10	55.04	-	7.53*	70.3	55.6	+2.0 49.8	+2.6 62.3	+0.89 X 11.39	<=	130	A1C	R	330	121.0	4313 020 72720
70.26	57.14	-	6.56*	70.16	57.54	+1.02 61.66 -1.02	+1.2 64.08 -0.5	+0.5 X 9.8	=>	140	A1	R	330	88.5	4313 020 72340
70.26	57.16	-	6.55*	NOM 70.1	NOM 57.4	+2.1 40.6	=> 64.0	+0.8 X 10.0	=>	140	A1	R	330	86.0	4313 020 72620
70.66	55.88	-	7.35*	70.8	55.88	+1.39 16.31	+4.4 55.2	+0.88 X 16.01	=>	110	A1C	R	330	33.0	4313 020 72410
70.66	55.88	-	7.35*	70.8	55.88	+1.27 25.4	+4.2 60.8	+0.87 13.85	=>	120	A1C	R	330	62.0	4313 020 72380
70.66	55.88	-	7.35*	70.8	55.88	+1.8 35.1	+4.2 60.8	+0.88 X 13.85	+0.4 6.99	120	A1C	R	330	85.6	4313 020 72580
70.95	57.0	-0.37	7.35*	71.1	57.0	+1.0 39.4 -1.0	+3.0 60.3	21.4 -1.2	6.95 -0.4	120	A1B	R	380	86.0	4313 020 72910
70.95	57.0	-0.37	7.35*	71.1	57.0	+1.0 39.4 -1.0	+3.0 60.3	21.4 -1.2	6.95 -0.4	120	A3B	R	330	85.0	4311 021 32590 4311 021 35600 4311 021 35610
71.1	-	-	7.65*	71.1	55.7	+1.0 49.4 -1.0	+1.5 61.8 -1.5	+0.6 22.0 -0.6	=>	120	A1C	R	380	121.0	4311 021 34600
71.1	57.0	-0.3	7.35*	71.1	57.0	+1.0 49.4 -1.0	+3.0 60.3	21.4 -1.2	6.95 -0.4	120	A3B	R	330	108.0	4322 020 66170 4322 020 66040 4322 020 66070

FERROXDURE
MAGNET TYPE LIST

Concave-convex segments (continued)

gauge						segment									
d _o mm	d _i mm	ecc. mm	s mm	d _o mm	d _i mm	l mm	w mm	h, h ₁ mm	t mm	α deg	shape	or.	FXD	m g	catalogue no.
71.1	57.0	-0.3	7.35	71.1	57.0	+1.0 49.4 -1.0	+3.0 60.3	21.4 -1.2	6.95 -0.4	120	A3B	R	380	108.0	4322 020 66110
71.2	61.0	-1.9	7.1	71.2	61.0	+1.8 37.1	+3.2 64.4	+1.2 24.4	+0.5 6.4	120	A3B	R	380	101.0	4322 020 66100
72.0	57.2	-	7.4	72.0	57.2	+1.0 27.0 -1.0	+1.75 62.0 -1.75	22.5 -1.0	-	120	A1BD	R	330	57.0	4311 021 34490 4311 021 32250 4311 021 32260
72.0	57.2	-	7.4	72.0	57.2	+1.0 30.0 -0.9	+1.75 62.0 -1.75	22.5 -1.0	-	120	A1BD	R	330	67.0	4311 021 33750 4311 021 33760
72.0	57.2	-	7.4	72.0	57.2	+1.0 40.0 -1.0	+1.75 62.0 -1.75	22.5 -1.0	-	120	A1BD	R	330	85.0	4311 021 33090 4311 021 33100
72.08	57.34	-	7.37	72.12	57.9	+0.38 27.23 -0.38	62.71	+0.38 21.79 -0.38	>> 6.86	120	A1	R	330	62.5	4313 020 72250
72.08	57.34	-	7.37	72.12	57.9	+1.68 35.26	62.71	+0.38 21.79 -0.38	>> 6.86	120	A1	R	330	88.0	4313 020 72570
82.16	68.0	-0.32	7.4	82.16	68.0	+1.2 55.25 -1.0	+1.5 71.5	+0.6 24.5	7.3 -0.5	120	A3BC	R	330	148.0	4311 021 35170 4311 021 35140 4311 021 35150
86.08	69.7	-	8.19	86.22	69.7	+2.0 49.0	+2.5 78.5	+1.0 29.5	8.0 -0.6	140	A1BC	R	S 270	173.0	4313 020 72860
86.08	69.7	-	8.19	86.22	69.7	+1.0 50.0 -1.0	+3.0 78.5	+0.5 30.0 -0.5	8.0 -0.6	140	A1BC	R	S 330	173.0	4313 020 72980
86.08	69.7	-	8.19	86.22	69.7	+3.0 58.0	+1.5 78.5 -1.5	+1.0 29.5	8.0 -0.6	140	A1BC	R	S 270	208.0	4313 020 72890

gauge					segment										
d _o mm	d _j mm	ecc. mm	s mm	d _o mm	d _j mm	l mm	w mm	h, h _h mm	t mm	α deg	shape or.	FXD	m g	catalogue no.	
86.08	69.7	-	8.19	86.22	69.7	58.0	78.5	29.2	8.0	140	A1BC	R	330	203.0	4313 020 72880 4313 020 72940 4313 020 72950
95.0	77.0	-	9.0	95.0	77.0	72.0	85.0	33.0	8.8	135	A1B	R	330	300.0	4311 021 35370
95.0	81.2	-	6.9	95.0	81.2	25.0	52.0	13.0	-	65	A1B	R	330	42.0	4311 021 33450 4311 021 33000 4311 021 33010
102.2	82.0	+0.1	10.0	102.2	82.0	66.0	60.0	18.0	9.9	70	A1	R	270	187.0	4322 020 66360 4322 020 66340 4322 020 66350
102.2	82.0	+0.1	10.0	102.2	82.0	66.0	60.0	18.0	9.9	70	A1	R	330	187.0	4322 020 66390 4322 020 66820 4322 020 66430
102.2	83.0	+0.1	9.5	102.2	83.0	66.0	60.0	17.5	9.4	70	A1	R	270	178.0	4322 020 66310 4322 020 66320 4322 020 66330
102.2	83.0	+0.1	9.5	102.2	83.0	66.0	60.0	17.5	9.4	70	A1	R	380	183.0	4322 020 66370
102.2	83.0	+0.1	9.5	102.2	83.0	66.0	60.0	17.5	9.4	70	A1	R	330	178.0	4322 020 66820 4322 020 66400 4322 020 66410
103.36	88.78	-	7.29	103.36	88.78	24.6	54.36	38.4	6.89	65	A1	R	330	47.0	4313 020 72420
107.6	93.3	-	7.15	107.7	93.3	26.5	85.0	24.0	7.0	100	A1C	R	375	83.0	4311 021 35190
109.2	94.0	-	7.6	108.6	94.0	27.0	59.0	14.0	7.8	60	A1	R	330	56.0	4311 021 33850 4311 021 33860

FERROXDURE
MAGNET TYPE LIST

Concave-convex segments (continued)

gauge						segment									
d _o mm	d _i mm	ecc. mm	s mm	d _o mm	d _i mm	l mm	w mm	h _h mm	t mm	α deg	shape	or.	FXD	m g	catalogue no.
113.0	83.0	-	15.0	* 113.0	* 83.0	+2.6 66.0	+1.0 60.0 -1.0	+0.6 23.0 -0.6	14.9 -0.5	70	A1	R	330	276.0	4322 020 66300
116.0	91.0	-	12.5	* 116.0	* 91.0	39.0 -1.0	+1.0 41.5 -1.0	15.75 -0.5	12.6 -0.5	45	A1	P	330	96.0	4311 021 36970 4311 021 35330 4311 021 35340
130.2	95.8	0.2	17.4	* 130.2	* 95.8	+3.1 127.0 -3.1	+1.5 59.5 -1.5	+1.2 22.2 -1.2	17.3 -0.5	60	A1	R	380	603.0	4311 021 35610
160.0	122.0	-	19.0	* 160.0	* 122.0	+2.0 100.0 -2.0	+1.5 61.0 -1.5	+1.0 24.0 -1.0	18.9 -0.6	50	A1	R	S 380	550.0	4311 021 35600
161.04	135.38	-	12.83	* 161.04	* 135.38	+1.34 71.63 -1.34	+1.0 101.8 -1.0	+0.89 28.0 -0.89	12.62 -0.38	85	A2	R	330	450.0	4311 021 35650
179.0	152.0	-	13.5	* 179.0	* 152.0	+1.5 75.0 -1.5	+1.75 68.25 -1.75	+0.5 18.5 -0.5	13.4 -0.4	45	A1	R	400	330.0	4311 021 35660
224.0	157.0	-2.4	31.1	* 224.0	* 157.0	+4.0 100.0 -4.0	+4.0 76.0	+0.8 37.0 -0.8	31.0 -0.7	50	A1	P	S 380	1211.0	4311 021 35590

Flat-concave segments

gauge				segment						catalogue no.				
d _o mm	d _i mm	ecc. mm	s mm	d _o mm	d _i mm	l mm	w mm	h, h _■ mm	t mm	α deg	shape	or.	FXD	m g
-	-	-	-	-	31 +0,6	54 ±0,5	28,6 +1,0 -2,0	10,5 ±0,5	6,8 -0,3	80	B1	p	330	64,5
														4311 021 32740 4311 021 32090 4311 021 32100

Concave-convex segments with slots

gauge				segment						catalogue no.				
d _o mm	d _i mm	ecc. mm	s mm	d _o mm	d _i mm	l mm	w mm	h, h _■ mm	t mm	α deg	shape	or.	FXD	m g
110,2	94,7	-0,2	7,95	110,2 +0,8	≥ 94,7	27 ±0,65	54 ±0,8	14,45 ±0,4	7,65 -0,5	60	A1u p = 45,6	r*	330	51
														4311 021 33040 — —

Flat-convex segments

gauge				segment						catalogue no.				
d _o mm	d _i mm	ecc. mm	s mm	d _o mm	d _i mm	l mm	w mm	h, h _■ mm	t mm	α deg	shape	or.	FXD	m g
-	-	-	-	114 ±2	-	25 ±0,5	39,5 ±0,8	9,5 ±0,2	-	40	C	p	330	39,5
														4311 021 30130 — —
-	-	-	-	148 ±4	-	27 ±0,65	40,5 ±1	15 ±0,2	-	30	C	p	330	87,5
														4311 021 34500 4311 021 34510

ISOTROPIC PLASTIC-BONDED FERROXDURE
(section 6)

BLOCKS, STRIPS, ROLLS

E = Magnetized perpendicular to a x b
 R_n = Magnetized laterally, n poles on one
 a x b face, poles parallel to side a
 A = Magnetized axially

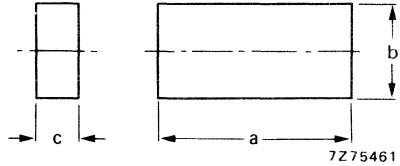

a mm	b mm	c mm	FXD		pole marking	sticking force N	catalogue number
150 m	9 ± 0,3	3 ± 0,1	P40B	R2		0,25 (Δ = 0,5)	4312 020 70020
40 ± 0,6	10 ± 0,2	6 ± 0,15	P40B				3122 134 91890
40 ± 0,6	6 ± 0,15	6 ± 0,15	P40B	A			3122 134 92090
70 ± 0,6	6 ± 0,15	6 ± 0,15	P40B	A			3122 134 92080

RODS, ROTORS

A = Magnetized axially
 B = Magnetized diametrically

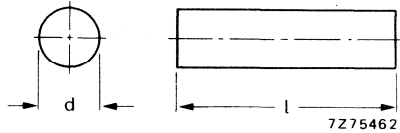

d mm	l mm		FXD		pole marking	catalogue number
5 ± 0,2	30 - 1		P40B	A	yes	3122 104 94980
5 ± 0,2	40 - 1		P40B	A	yes	3122 104 90360
12 ± 0,6	3 ± 0,1		P30	B		4312 020 72020

FERROXDURE MAGNET TYPE LIST

RINGS

- B = Magnetized diametrically
 Wn = Magnetized laterally, n poles
 on inner circumference, neutral
 zones axial
 Y = Magnetized radially, N-pole inside
 U = Unmagnetized

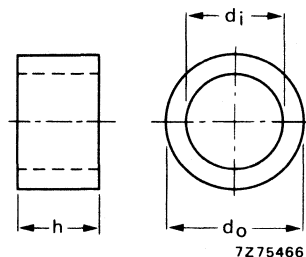

d_o mm	d_i mm	h mm	FXD			catalogue number
14,7 - 0,1	$\square 4,1 \begin{smallmatrix} +0,1 \\ -0,2 \end{smallmatrix}$	$25,5 \pm 0,1$	SP170	B		4203 014 80200
12,4 - 0,4		$7 + 0,5$	P40B	Y		3122 104 93530
22,5 - 0,15	$17,55 + 0,08$	$22,4 \pm 0,15$	SP130	W2		4222 017 20220
24,9 - 0,15	$19,55 + 0,25$	$14,5 \pm 0,2$	SP130	W2		4322 010 83600
$28 \pm 0,1$	$23 \pm 0,2$	$25,5 \pm 0,2$	SP130	W2		4304 099 10060

U-SHAPED SEGMENT

- X = Magnetized radially, S-pole inside

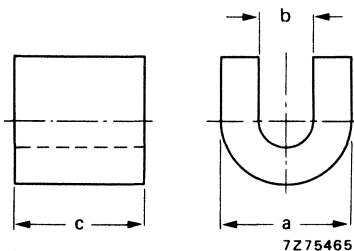

a mm	b mm	c mm	FXD			catalogue number
$12 + 0,6$	$5,2 \pm 0,1$	$12 \pm 0,3$	P40B	X		3122 104 93770

PLATES with hole

E = Magnetized perpendicular to a x c
Rn = Magnetized laterally, n poles on one a x b face, poles parallel to side a

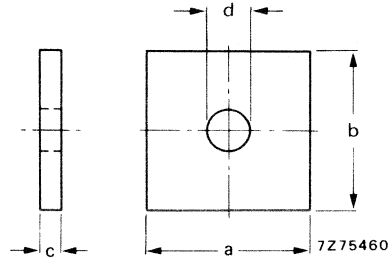

a mm	b mm	c mm	d mm	FXD			catalogue number
13 + 0,6	13 + 0,6	3 ± 0,15	3 - 0,3	P30	E		4312 020 76990
13 + 0,6	40 - 1	3 ± 0,15	3 - 1	P40B	E	hole not in centre	3122 104 95000 ←

PLATES with slot

E = Magnetized perpendicular to a x c

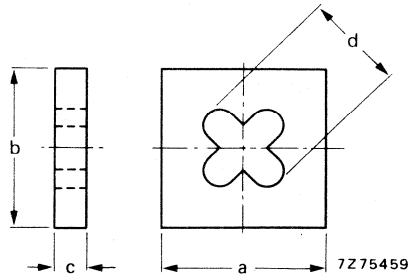

a mm	b mm	c mm	d mm	FXD			catalogue number
8,4 - 0,6	8,4 - 0,6	3 ± 0,15	5,8 + 0,5	P30	E		3122 104 94120
10,6 - 0,6	10,6 - 0,6	3 ± 0,15	9	P30	E		3122 104 93540
11 + 0,6	11 + 0,6	3 ± 0,15	6,5 + 0,5	P30	E		3122 104 02720

RINGS with notches

W2 = Magnetized laterally, 2 poles on inner circumference, neutral zones axial

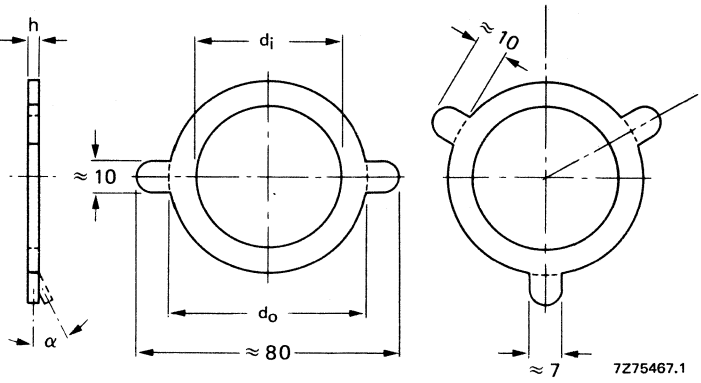

d_o mm	d_i mm	d mm	FXD		number of notches	α	catalogue number
→ 39 + 0,5	27 + 0,4	1,5 ± 0,1	SP10	W2	3	30°	3122 134 91290
→ 50 - 0,5	35,6 + 0,2	1,7 + 0,2	SP10	W2	1	0°	4312 020 72110
→ 50 - 0,5	35,6 + 0,2	1,7 + 0,2	SP10	W2	2	30°	3122 104 93980

RING with wings

B = Magnetized diametrically

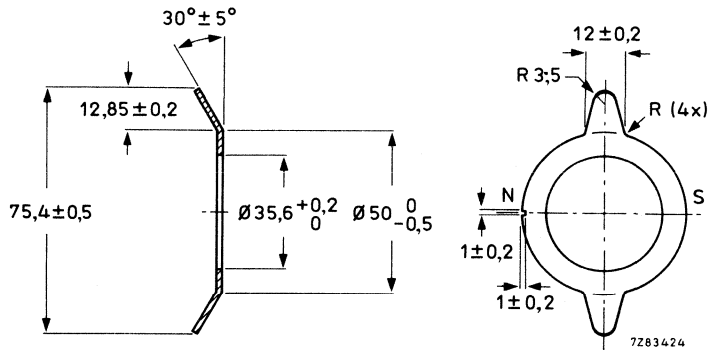

d_o mm	d_i mm	h mm	FXD			catalogue number
→ 50	35,6	1,7 + 0,2 - 0,0	SP10	B		3122 134 91870

RARE-EARTH MAGNET MATERIALS

RARE-EARTH HIGH ENERGY PERMANENT MAGNETS

INTRODUCTION

Rare-earth permanent-magnet materials are capable of providing a high stored energy. They combine this with high coercivity and a low temperature coefficient, to give permanent magnets with the small size and the high performance necessary to complement the increasing miniturization of electronic components.

Since their introduction, rare-earth materials have opened up new applications for permanent magnets, solving problems for which older materials proved unsuitable. Moreover, their unique characteristics have altered the design of many traditional transducers, reducing volume and increasing efficiency. The high coercivity of these materials allows the use of very short magnetic lengths, and their high remanence means that the use of mild-steel pole-pieces for flux concentration is often unnecessary.

Magnetic materials containing rare-earth elements are available under the designation RES (Rare Earth Sintering). The inter-metallic compound of cobalt and the rare-earth element samarium is called RES190. The manufacture of RES190 magnets is described below. Another inter-metallic compound containing iron, boron and the rare-earth element neodymium is currently under development (RES270). Detailed information on the properties of RES190 and RES270 are given later in this chapter.

Manufacturing process for RES190 magnets

1. Alloy production.
The alloy is produced from samarium oxide and cobalt powder, using the reduction/diffusion process.
2. Milling of the alloy.
To produce single crystal particles with the desired size and sinter reactivity (containing no grain boundaries and only one preferred axis of magnetization).
3. Composition control and adjustment.
4. Particle alignment and pressing.
Compaction by die-pressing or by isostatic pressing. Particle alignment is done with a high homogenous magnetic field during pressing.
5. Sintering and heat treatment.
Sintering is carried out in an inert atmosphere or under vacuum, resulting in a magnet with density greater than 95% of the theoretical density of 8,6 g/cm³. To increase coercive force, a post-sintering heat treatment is required.
6. Machining.
Sintered samarium-cobalt magnets are hard and brittle and must be machined with silicon carbide or diamond grinding wheels.
7. Magnetizing.

Applications

The relative volume of a system is of paramount importance in many applications. Here RES types have a clear advantage over other magnetic materials.

As previously mentioned the higher working flux density of RES magnets often makes flux concentrating pole-pieces unnecessary. This results in lower flux leakage and magnetomotive force drop, so less material is required. In dynamic applications, such as motors, the magnets are exposed to external demagnetizing fields. Since recoil takes place along the main BH curve, the reduced allowance for demagnetization results in a shorter magnetic length.

Motors, see Fig. 1

Permanent magnet motors using RES magnets are finding widespread use especially as:

- miniature motors in battery operated equipment,
- miniature stepping motors for clocks and watches,
- high-efficiency compact servo motors with power rating up to 15 kW,
- actuating motors for automatic cameras,
- drive motors in miniature cassette players and floppy disc drives,
- industrial stepping motors,
- miniature synchronous motors.

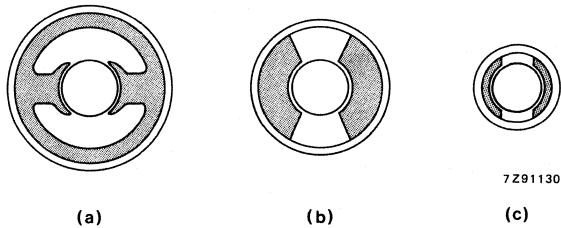

Fig. 1 Cross-section through motors of identical armature diameter and speed-torque characteristics. Note the progressive size reduction from the wound-field design (a) achievable with Ferroxdure ceramic stator magnets (b) and RES stator magnets (c).

Position transducers, see Figs 2, 3

These are used in:

- focusing systems for Compact Discs,
- moving-coil instruments,
- head/arm positioning actuators in computers.

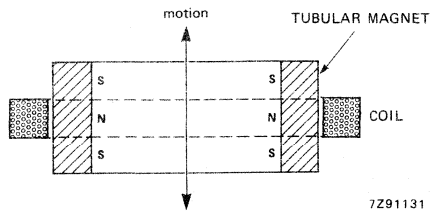

Fig. 2 Elements of a linear voltage transducer used in the automatic focusing control of a Compact Disc player. The transducer produces a force of 100 mN at a m.m.f. of 25 ampere-turns in the coil; its displacement of 1 mm in each direction is essentially linear with voltage.

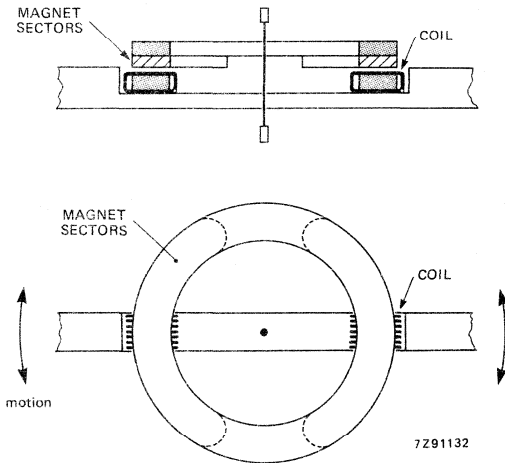

Fig. 3 Outline and cross-section of an oscillatory actuator using RES magnets, also developed for the Compact Disc player.

Audio frequency transducers, see Fig. 4

These are used in:

- microphones,
- moving-coil pick-ups for record players,
- earphones,
- loudspeakers.

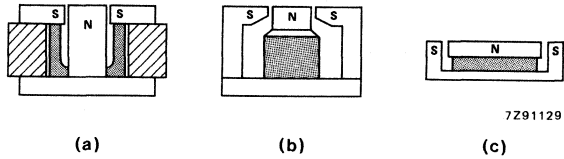

Fig. 4 Relative size of loudspeaker magnet systems using FXD330 ferrite (a), Ticonal 550 alloy (b), RES190 (c). The last one is not only very compact, but also completely screened, making it very suitable for miniature equipment.

Other applications

These include:

- magnetic bearings, couplings, holding devices, dampers,
- separators (e.g. metals from plastic),
- microwave focusing systems,
- Hall-effect keyboards,
- tachometer sensors,
- high-speed printer hammer-banks,
- medical items (e.g. dentures, pacemakers).

RES190

GENERAL

The B-H characteristic of RES190 material is substantially linear in the second quadrant of the hysteresis loop, as shown in Fig. 5. This property, combined with a recoil permeability of approximately 1,05 and very high polarization coercivities, makes for stable operation. The main properties of RES190 are given in Table 1.

Specifications relate to tests carried out on pieces made from normal production batches of material. The test pieces have dimensions of approximately 25 mm dia x 5 mm.

In general, magnets conform to these specifications, but owing to variations in size, shape and method of manufacture, these limits cannot always be realized or indeed checked by measurements on the magnet. For this reason, guaranteed parameters are laid down in the relevant component specification.

General specifications for RES190

Ambient temperature 25 ± 2 °C, unless otherwise stated.

Temperature coefficient of B_r (−60 to + 180 °C)	−0,05 %/K
Temperature coefficient of H_{cJ} (20 to 150 °C)	−0,3 %/K
Recoil permeability	1,05
Irreversible flux loss*	< 4 %
Resistivity	$5 \times 10^{-7} \Omega \cdot m$
Curie point	720 °C
Recommended initial magnetizing field	> 1800 kA/m
Maximum continuous operating temperature	250 °C
Density	$8,3 \times 10^3 \text{ kg/m}^3$
Hardness (Vickers)	500
Young's modulus	$1,5 \times 10^5 \text{ N/mm}^2$
Coefficient of linear expansion,	
parallel to magnetic axis	$6 \times 10^{-6}/K$
normal to magnetic axis	$12 \times 10^{-6}/K$
Thermal conductivity	10 W/mK
Bending strength	120 N/mm ²
Compressive strength	900 N/mm ²

* Measured on a disc sample, under open circuit conditions, with $B/\mu_0 H = -1$, after 3000 h at 150 °C.

Table 1 Properties of RES190 material

Remanence	B_r	min. 870 mT typ. 890 mT
Coercivity	H_{cB}	min. 620 kA/m typ. 670 kA/m
Polarization coercivity	H_{cJ}	min. 1100 kA/m
Maximum BH product	$(BH)_{max}$	min. 144 kJ/m ² typ. 154 kJ/m ²
Magnetic flux density corresponding to $(BH)_{max}$	B_d	typ. 440 mT
Magnetic field strength corresponding to $(BH)_{max}$	H_d	typ. 350 kA/m

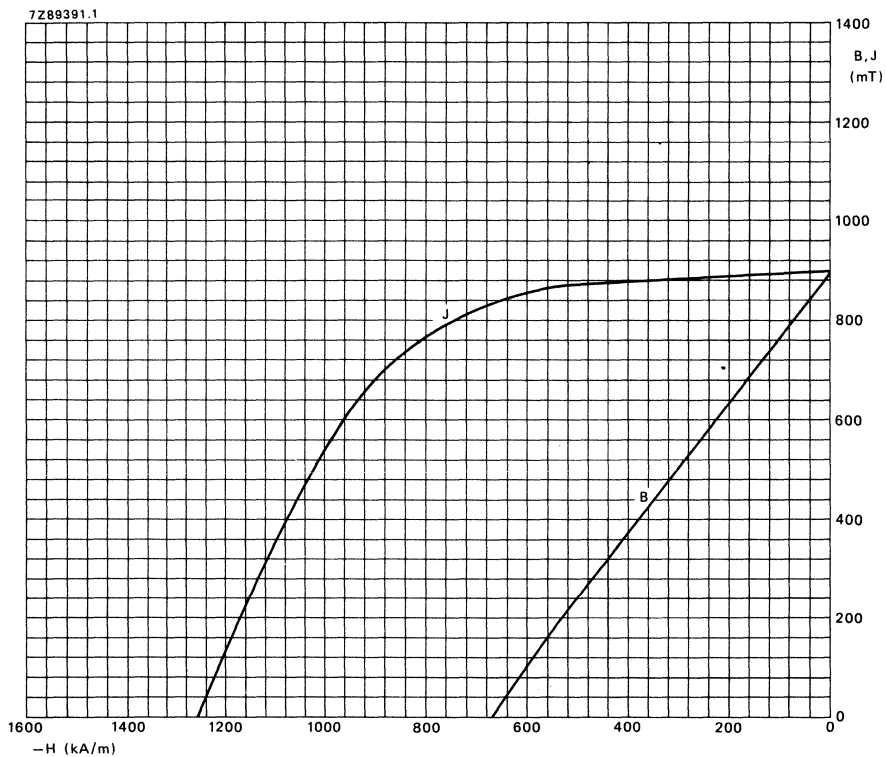

Fig. 5 Typical demagnetization curve RES190 samarium cobalt at 25 °C.

MAGNETIZATION

RES magnets can be supplied magnetized or unmagnetized. Self-demagnetization at ambient temperature is negligible, but magnetized products may suffer not only mechanically if handled carelessly but also magnetically. Wherever possible, magnets should be magnetized after assembly.

The figures quoted for minimum magnetizing field strength relate to magnets that have not been magnetized after the final production heat treatment. Subsequent magnetizing operations require much stronger fields than used in the initial magnetization (up to three times as strong). Figs 6 and 7 show the effect of an increasing magnetic field on the properties of a magnet. Note the marked effect on coercivity. The magnets can be demagnetized by applying a sufficiently high reverse field. However, such an action should be avoided if at all possible in view of the material's high coercivity and the subsequent magnetic field then required to remagnetize it. Heating the magnet above its Curie point will also demagnetize it, but this should not be attempted since its magnetic properties could suffer.

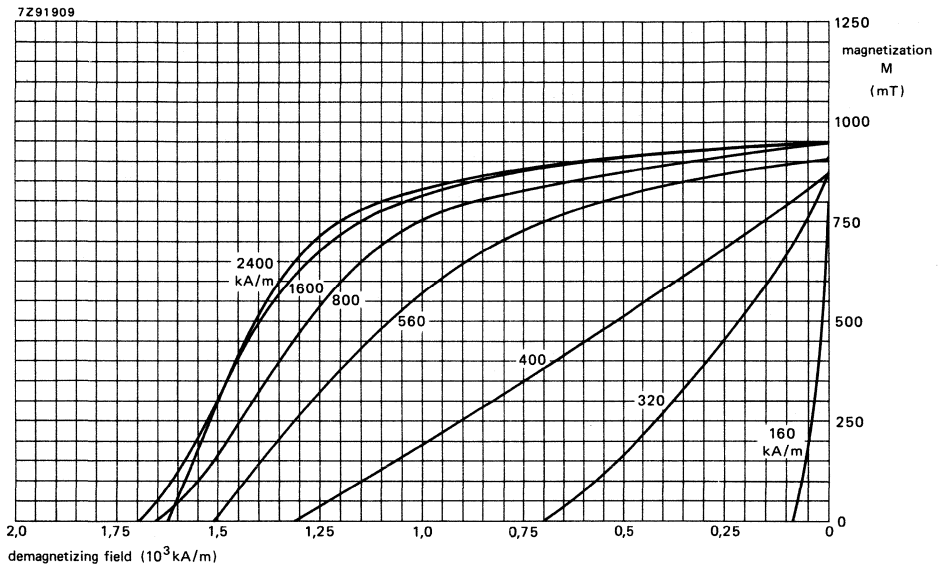

Fig. 6 Thermally demagnetized RES190 magnets; dependence of coercivity on initial magnetizing field.

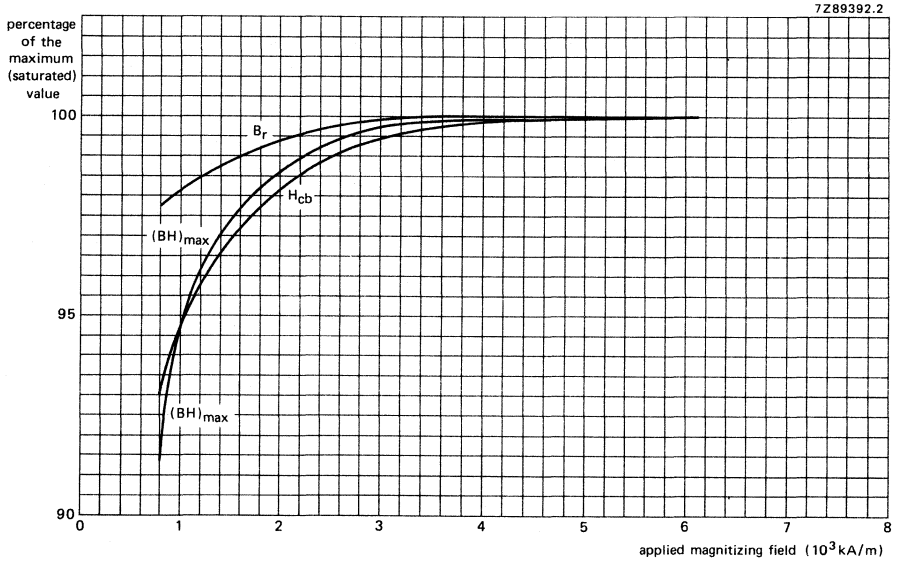

Fig. 7 B_r , H_{cB} and $(BH)_{max}$ as a percentage of the maximum obtained (saturated) value as a function of magnetizing field strength. Values are typical for a RES190 magnet not previously magnetized.

EFFECT OF TEMPERATURE ON ELECTRICAL PROPERTIES

The working point induction of a magnet falls with increasing temperature. The losses that occur with rising temperature fall into three categories: reversible, irreversible and irrecoverable.

Reversible losses, caused by the effect of temperature on the saturation polarization, are expressed in terms of the temperature coefficient of remanence, which for RES190 magnets is very low: $-0,05\%/K$, compared with $-0,2\%/K$ for Ferroxdure.

Irreversible losses, recoverable by remagnetization, are caused by elemental parts of the magnet becoming demagnetized by thermal agitation. The extent to which this occurs depends upon the magnetic working point (the demagnetizing field strength), temperature and time at that temperature so the data given in this Handbook relate to losses at a specified working point.

Irrecoverable losses, that cannot be recovered by remagnetization are caused by metallurgical changes within the magnet, such as oxidation. Improvements in production technology have reduced this problem significantly for normal working conditions. The maximum recommended operation temperature should, however, not be exceeded.

To provide improved temperature stability needed in some applications, the magnets can undergo an ageing operation. This involves heating the magnets at the relevant working point for several hours at a temperature somewhat in excess of the expected maximum operating temperature.

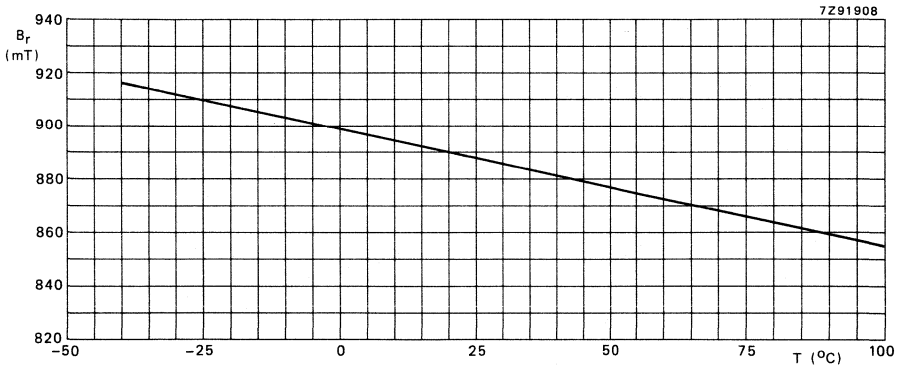

Fig. 8 Typical reversible losses for RES190. B_r versus temperature.

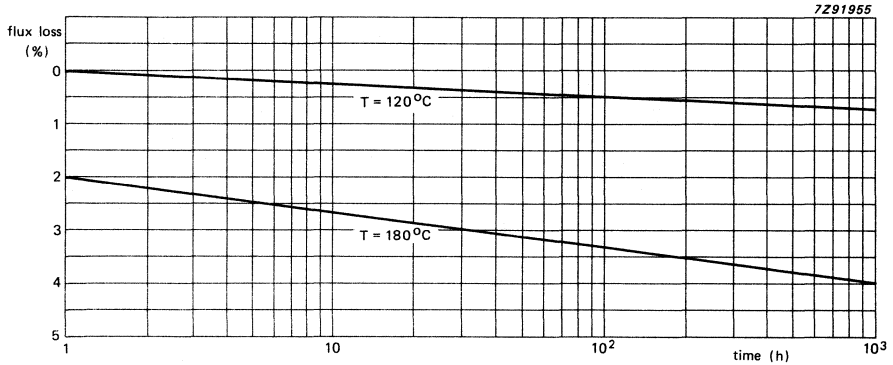

Fig. 9 Irreversible flux losses measured on a disc sample with $B/\mu_0H = 1,5$.

PRODUCT SHAPES AND TOLERANCES

During sintering, the magnet shrinks. The amount of shrinkage depends upon production factors and upon the magnet's final shape and size. This results in some variation in magnet dimensions, so for closer tolerances the surfaces must be machined. Because of the material's hardness it is usually ground with diamond coated wheels.

Cutting tolerances for small blocks cut from bigger blocks are $\pm 0,1$ mm.

Grinding these pieces afterwards or grinding as sintered pieces, for example flat grinding or centreless grinding, gives tolerances of $\pm 0,05$. Smaller tolerances are possible but more expensive. See table 2 for standard tolerances. All above mentioned tolerances are only meant as a guideline for design. Because sintered rare-earth magnets are hard and brittle, they must be handled with care to prevent cracking or chipping. In Table 3 some of our currently available products in RES190 are listed but other types and shapes, with, if necessary, different magnetization may be made available upon request.

Table 2 Tolerances for sintered RES products

product dimensions mm	in press direction mm	tolerances perpendicular to press direction mm	thin walled mm
< 5*	$\pm 0,2$	$\pm 0,1$	$\pm 0,2$
5 to 10	$\pm 0,3$	$\pm 0,2$	$\pm 0,3$
10 to 15	$\pm 0,4$	$\pm 0,3$	$\pm 0,4$
15 to 20		$\pm 0,4$	$\pm 0,5$
20 to 25		$\pm 0,5$	
> 25		$\pm 2,5\%$	

* Products with dimensions < 5 mm are in most cases cut products; tolerances as per type lists for blocks and discs and rings.

BLOCKS – RES190

Orientation: perpendicular to a x b

Where more than one catalogue number is mentioned in the table, the first is of an unmagnetized product, the second is of a magnetized product.

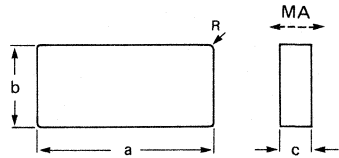

7Z52596.2

a mm	b mm	c mm	mass g	catalogue number
3 ± 0,1	2 ± 0,1	1 ± 0,1	0,05	— 4313 059 68080
3 ± 0,1	3 ± 0,1	1 ± 0,1	0,07	— 4313 059 68140
4 ± 0,1	4 ± 0,1	2 ± 0,15	0,25	— 4313 059 68330
8 ± 0,2	5 ± 0,2	3 ± 0,1	1,0	— 4313 059 68350
13 ± 0,2	7 ± 0,2	2,5 ± 0,1	1,9	— 4313 059 68370
18,5 ± 0,4	8,3 ± 0,3	4,3 ± 0,05	5,5	— 4313 059 68380
24 ± 0,7	7,3 ± 0,05	2 ± 0,05	2,9	— 4313 059 68440
30 ± 0,7	8,5 ± 0,05	2 ± 0,05	4,2	— 4313 059 68400
42 ± 1,5	42 ± 1,5	10 ± 0,1	148	4313 059 68300 —
52 ± 1,5	48 ± 1,5	10 ± 0,1	207	4313 059 68500 —
63 ± 1,5	36 ± 1,5	10 ± 0,1	188	4313 059 68270 —

SEGMENT – RES190

unmagnetized

mass 5,6 g

catalogue number:

4313 059 69020

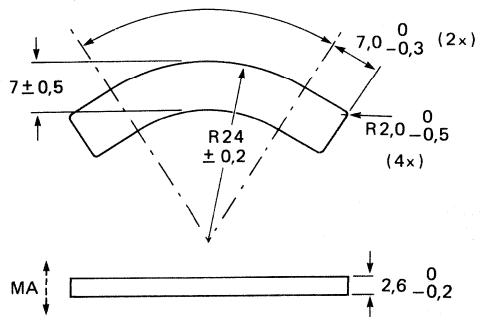

7Z91905

**RARE-EARTH
RES190
MAGNET TYPE LIST**

DISCS and RINGS – RES190

Orientation: axial

Where more than one catalogue number is mentioned in the table, the first is of an unmagnetized product, the second is of a magnetized product.

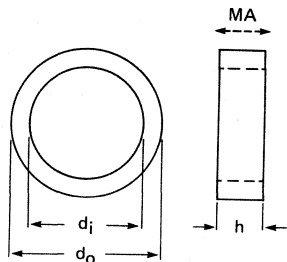

7Z91906

d_o mm	d_i mm	h mm	mass g	catalogue number
$5 \pm 0,15$		$1,5 \pm 0,05$	0,25	– 4313 059 66040
$5 \pm 0,15$		$2,0 \pm 0,05$	0,35	– 4313 059 66070
$6 \pm 0,2$		$4,0 \pm 0,2$	0,9	– 4313 059 66000
$8 \pm 0,05$		$5 \pm 0,1$	2,1	– 4313 059 66190
$10,5 - 0,5$		$1,5 - 0,1$	1,0	– 4313 059 66030
$10 \pm 0,2$		$4 \pm 0,2$	2,6	– 4313 059 66020
$14 \pm 0,2$		$4,0 \pm 0,2$	5,1	– 4313 059 66010
$17,5 \pm 0,5$		$2,5 \pm 0,05$	5,0	4313 059 66100 –
$25 \pm 0,1$		$10 \pm 0,05$	41	4313 059 66200 –
$14,2 - 0,2$	$10,8 \pm 0,3$	$2,65 \pm 0,05$	1,4	– 4313 059 67060
$19,5 \pm 0,05$	$5,4 \pm 0,3$	$2 \pm 0,05$	4,6	4313 059 67050 –
$72 \pm 0,2$	$38 \pm 0,3$	$4 \pm 0,1$	97	4313 059 67030 –

RING – RES190

Orientation: diametrical
unmagnetized
mass: 6,8 g
catalogue number:
4203 031 60100

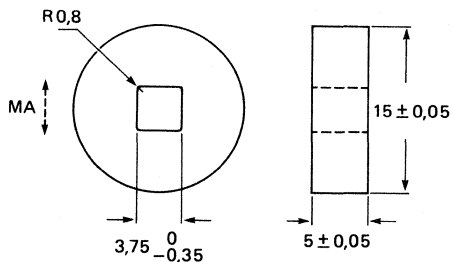

7Z91907

DEVELOPMENT DATA

This data sheet contains advance information and specifications are subject to change without notice.

RES270

GENERAL

A new rare-earth magnet material under development is based on a compound of neodymium, iron and boron (NdFeB). This not only has better material properties than the rare earth compound based on samarium and cobalt (SmCo), grade RES190, it will also be more readily available since basic raw materials have fewer supply restrictions than Sm or Co.

The development efforts are basically aimed at a NdFeB magnet material with a $(BH)_{\max}$ of 216 kJ/m³ (27 MGsOe). This material will be called RES270 and its properties are listed in the table below. Samples in simple shapes are available on request.

General specifications for RES270, compared with RES190 and FXD380

Ambient temperature 25 ± 2 °C, unless otherwise stated

	RES270	RES190	FXD380	
Temperature coefficient of B_r (20 to + 150 °C)	-0,14	-0,04	-0,2	%/K
Temperature coefficient of H_{cJ} (20 to + 150 °C)	-0,6	-0,05	0,34	%/K
Recoil permeability	1,05	1,05	1,1	
Curie point	310	720	450	°C
Recommended initial magnetizing field	> 1600	1800		kA/m
Maximum continuous operating temperature	140	250	350	°C
Density	7,2	8,3	4,75	$\times 10^3$ kg/m ³
Hardness (Vickers)	600	500		

Table 1 Properties of RES270 material (typical values)

Remanence	B_r	1,1 T
Coercivity	H_{cB}	750 kA/m
Polarization coercivity	H_{cJ}	835 kA/m
Maximum BH product	$(BH)_{max}$	216 kJ/m ³ (27) (MGsOe)
Magnetic flux density corresponding to $(BH)_{max}$	B_d	570 mT
Magnetic field strength corresponding to $(BH)_{max}$	H_d	400 kA/m

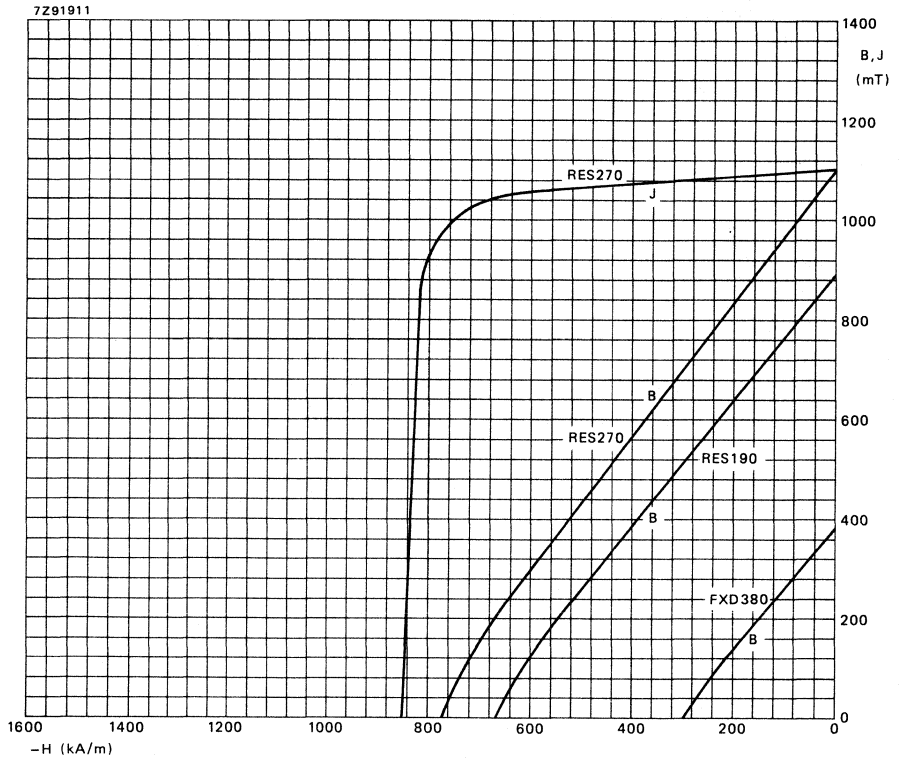

Fig. 10 Typical demagnetization curve of RES270, compared with RES190 and FXD380.

DEVELOPMENT DATA

This data sheet contains advance information and specifications are subject to change without notice.

RARE-EARTH RES270 MATERIAL SPECIFICATION

APPLICATIONS

All rare-earth magnets, including NdFeB, are particularly effective for those applications where limited space is available and miniaturization of the system and efficiency increase is necessary. There is a much wider scope of applications for NdFeB magnets than for existing rare-earth magnets. The following application areas are of particular interest:

- motors,
- audio frequency transducers,
- position transducers,
- medical, instrumental or mechanical items.

EFFECT OF TEMPERATURE ON ELECTRICAL PROPERTIES

The working point induction of a magnet falls with increasing temperature. The losses that occur with rising temperature fall into two categories: reversible, and irreversible.

Reversible losses, expressed in terms of temperature coefficient of remanence are higher for NdFeB magnets (0,14 %/K) than for SmCo magnets. Also the reversible temperature coefficient of H_{cJ} (-0,6 %/K) is higher for NdFeB than for SmCo magnets.

Irreversible losses, recoverable by remagnetization, are caused by elemental parts of the magnet becoming demagnetized by thermal agitation. The extent to which this occurs depends upon the magnetic working point (the demagnetizing field strength) and upon temperature. As remagnetization is rarely practical, the maximum recommended operating temperature of 140 °C should not be exceeded, in order to avoid extremely high irreversible losses.

Magnetization

With regard to magnetization, NdFeB magnets behave like SmCo magnets, although a slightly lower field of 1600 kA/m can be used for RES270 magnets.

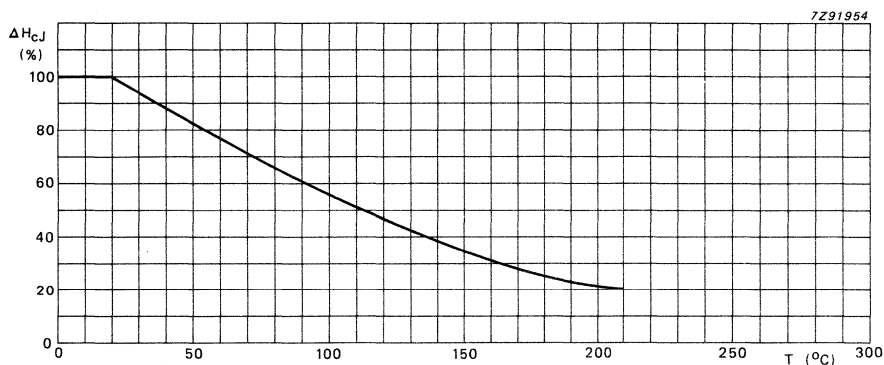

Fig. 11 Variation $\Delta H_{cJ}/H_{cJ}$ of normalized intrinsic coercivity versus temperature (normalized to H_{cJ} at 20 °C).

NOTES

Argentina: PHILIPS ARGENTINA S.A., Div. Elcoma, Vedia 3892, 1430 BUENOS AIRES, Tel. 541-7141/7242/7343/7444/7545.

Australia: PHILIPS INDUSTRIES HOLDINGS LTD., Elcoma Division, 11 Waltham Street, ARTARMON, N.S.W. 2064, Tel. (02) 439 3322.

Austria: ÖSTERREICHISCHE PHILIPS BAUELEMENTE INDUSTRIE G.m.b.H., Triester Str. 64, A-1101 WIEN, Tel. 62 91 11.

Brazil: N.V. PHILIPS & MBLE ASSOCIATED, 9 rue du Pavillon, B-1030 BRUXELLES, Tel. (02) 242 7400.

Brazil: IBRAPE, Caixa Postal 7383, Av. Brigadeiro Faria Lima, 1735 SAO PAULO, SP, Tel. (011) 211-2600.

Canada: PHILIPS ELECTRONICS LTD., Elcoma Division, 601 Milner Ave., SCARBOROUGH, Ontario, M1B 1M8, Tel. 292-5161.

Chile: PHILIPS CHILENA S.A., Av. Santa Maria 0760, SANTIAGO, Tel. 39-4001.

Colombia: IND. PHILIPS DE COLOMBIA S.A., c/o IPRELENZO LTD., Cra. 21, No. 56-17, BOGOTA, D.E., Tel. 2497624.

Denmark: MINIWATT A/S, Strandlodsvej 2, P.O. Box 1919, DK 2300 COPENHAGEN S, Tel. (01) 54 11 33.

Finland: OY PHILIPS AB, Elcoma Division, Kaivokatu 8, SF-00100 HELSINKI 10, Tel. 17271.

France: R.T.C. LA RADIOTECHNIQUE-COMPELEC, 130 Avenue Ledru Rollin, F-75540 PARIS 11, Tel. 4338 8000.

Germany (Fed. Republic): VALVO, UB Bauelemente der Philips G.m.b.H., Valvo Haus, Burchardstrasse 19, D-2 HAMBURG 1, Tel. (040) 3296-0.

Greece: PHILIPS HELLENIQUE S.A., Elcoma Division, 54, Syngrou Av., ATHENS 11742, Tel. 9215311/319.

Hong Kong: PHILIPS HONG KONG LTD., Elcoma Div., 15/F Philips Ind. Bldg., 24-28 Kung Yip St., KWAI CHUNG, Tel. (0)-245121.

India: PEICO ELECTRONICS & ELECTRICALS LTD., Elcoma Dept., Band Box Building, 254-D Dr. Annie Besant Rd., BOMBAY - 400025, Tel. 4930311/4930590.

Indonesia: P. T. PHILIPS-RALIN ELECTRONICS, Elcoma Div., Setiabudi II Building, 6th Fl., Jalan H.R. Rasuna Said (P.O. Box 223/KBY) Kuningan, JAKARTA - Selatan, Tel. 512572.

Ireland: PHILIPS ELECTRICAL (IRELAND) LTD., Newstead, Clonskeagh, DUBLIN 14, Tel. 69 3355.

Italy: PHILIPS S.p.A., Sezione Elcoma, Piazza IV Novembre 3, I-20124 MILANO, Tel. 2-6752.1.

Japan: NIHON PHILIPS CORP., Shuwa Shinagawa Bldg., 26-33 Takanawa 3-chome, Minato-ku, TOKYO (108), Tel. 448-5611.
(IC Products) SIGNETICS JAPAN LTD., 8-7 Sanbancho Chiyoda-ku, TOKYO 102, Tel. (03) 230-1521.

Korea (Republic of): PHILIPS ELECTRONICS (KOREA) LTD., Elcoma Div., Philips House, 260-199 Itaewon-dong, Yongsan-ku, SEOUL, Tel. 794-5011.

Malaysia: PHILIPS MALAYSIA SDN. BERHAD, No. 4 Persiaran Barat, Petaling Jaya, P.O.B. 2163, KUALA LUMPUR, Selangor, Tel. 77 44 11.

Mexico: ELECTRONICA, S.A de C.V., Carr. México-Toluca km. 62.5, TOLUCA, Edo. de México 50140, Tel. Toluca 91 (721) 613-00.

Netherlands: PHILIPS NEDERLAND, Marktgroep Elonco, Postbus 90050, 5600 PB EINDHOVEN, Tel. (040) 79 33 33.

New Zealand: PHILIPS NEW ZEALAND LTD., Elcoma Division, 110 Mt. Eden Road, C.P.O. Box 1041, AUCKLAND, Tel. 605-914.

Norway: NORSK A/S PHILIPS, Electronica Dept., Sandstuveien 70, OSLO 6, Tel. 68 02 00.

Peru: CADESA, Av. Alfonso Ugarte 1268, LIMA 5, Tel. 326070.

Philippines: PHILIPS INDUSTRIAL DEV. INC., 2246 Pasong Tamo, P.O. Box 911, Makati Comm. Centre, MAKATI-RIZAL 3116, Tel. 86-89-51 to 59.

Portugal: PHILIPS PORTUGUESA S.A.R.L., Av. Eng. Duarte Pacheco 6, 1009 LISBOA Codex, Tel. 68 31 21.

Singapore: PHILIPS PROJECT DEV. (Singapore) PTE LTD., Elcoma Div., Lorong 1, Toa Payoh, SINGAPORE 1231, Tel. 3502000.

South Africa: EDAC (PTY.) LTD., 3rd Floor Rainer House, Upper Railway Rd. & Ove St., New Doornfontein, JOHANNESBURG 2001, Tel. 614-2362/9.

Spain: MINIWATT S.A., Balmes 22, BARCELONA 7, Tel. 301 63 12.

Sweden: PHILIPS KOMPONENTER A.B., Lidingövägen 50, S-11584 STOCKHOLM 27, Tel. 08/7821000.

Switzerland: PHILIPS A.G., Elcoma Dept., Allmendstrasse 140-142, CH-8027 ZÜRICH, Tel. 01-488 22 11.

Taiwan: PHILIPS TAIWAN LTD., 150 Tun Hua North Road, P.O. Box 22978, TAIPEI, Taiwan, Tel. 7120500.

Thailand: PHILIPS ELECTRICAL CO. OF THAILAND LTD., 283 Silom Road, P.O. Box 961, BANGKOK, Tel. 233-6330-9.

Turkey: TÜRK PHILIPS TICARET A.S., Elcoma Department, İnönü Cad. No. 78-80, P.K.504, 80074 ISTANBUL, Tel. 4359 10.

United Kingdom: MULLARD LTD., Mullard House, Torrington Place, LONDON WC1E 7HD, Tel. 01-5806633.

United States: (Active Devices & Materials) AMPEREX SALES CORP., Providence Pike, SLATERSVILLE, R.I. 02876, Tel. (401) 762-9000.
(Passive Devices) MEPCO/ELECTRA INC., Columbia Rd., MORRISTOWN, N.J. 07960, Tel. (201) 539-2000.
(Passive Devices & Electromechanical Devices) CENTRALAB INC., 5855 N. Glen Park Rd., MILWAUKEE, WI 53201, Tel. (414) 228-7380.
(IC Products) SIGNETICS CORPORATION, 811 East Arques Avenue, SUNNYVALE, California 94086, Tel. (408) 991-2000.

Uruguay: LUZIELECTRON S.A., Avda Uruguay 1287, P.O. Box 907, MONTEVIDEO, Tel. 91 43 21.

Venezuela: IND. VENEZOLANAS PHILIPS S.A., c/o MAGNETICA S.A., Calle 6, Ed. Las Tres Jotas, App. Post. 78117, CARACAS, Tel. (02) 2393931.

For all other countries apply to: Philips Electronic Components and Materials Division, International Business Relations, Building BAE, P.O. Box 218, 5600 MD EINDHOVEN, The Netherlands, Tel. +31 40 72 33 04, Telex 35000 phtncf

AS51

© Philips Export B.V. 1986

This information is furnished for guidance, and with no guarantee as to its accuracy or completeness; its publication conveys no licence under any patent or other right, nor does the publisher assume liability for any consequence of its use; specifications and availability of goods mentioned in it are subject to change without notice; it is not to be reproduced in any way, in whole or in part, without the written consent of the publisher.